

Source Water Protection Plan

Clay Roane Public Service District

PWSID 3300806

Clay County

June 2016

Prepared by:

Tetra Tech, Inc.

803 Quarrier Street, Suite 400

Charleston, WV 25314

In cooperation with:

Clay Roane PSD

WV Bureau for Public Health, Source Water Assessment and Protection Program

Region III Planning and Development Council

Potesta & Associates, Inc.



This page is intentionally blank.

John Beckman

Preparer's Name

Source Water Specialist

Title of Preparer

Tetra Tech, Inc.

Name of Contractor(s)/Consultant(s)

Note: Portions of this plan relative to the contingency and single source alternative study were completed by Potesta & Associates, Inc. Their complete report is included as Appendix D.

I certify the information in the source water protection plan is complete and accurate to the best of my knowledge.

M. Susan Beard Acting Board Chairman

Signature of responsible party or designee authorized to sign for water utility:

M. Susan Beard Acting Board Chairman

Print Name of Authorizing Signatory (see instructions):

Title of Authorizing Signatory:

06/09/2016

Date of Submission (mm/dd/yyyy):

This page is intentionally blank.

TABLE OF CONTENTS

1.0 PURPOSE	1
1.1 What are the benefits of preparing a Source Water Protection Plan?	1
2.0 BACKGROUND: WV SOURCE WATER ASSESSMENT AND PROTECTION PROGRAM	2
3.0 STATE REGULATORY REQUIREMENTS	3
4.0 SYSTEM INFORMATION	4
5.0 WATER TREATMENT AND STORAGE	5
6.0 DELINEATIONS	7
7.0 PROTECTION TEAM	9
8.0 POTENTIAL SOURCES OF SIGNIFICANT CONTAMINATION	12
8.1 Confidentiality of PSSCs.....	12
8.2 Local and Regional PSSCs	12
8.3 Prioritization of Threats and Management Strategies	14
9.0 IMPLEMENTATION PLAN FOR MANAGEMENT STRATEGIES	15
10.0 EDUCATION AND OUTREACH STRATEGIES	21
11.0 CONTINGENCY PLAN	25
11.1 Response Networks and Communication	25
11.2 Operation During Loss of Power.....	26
11.3 Future Water Supply Needs	27
11.4 Water Loss Calculation.....	28
11.5 Early Warning Monitoring System	29
12.0 SINGLE SOURCE FEASIBILITY STUDY	31
13.0 COMMUNICATION PLAN	32
14.0 EMERGENCY RESPONSE	33
15.0 CONCLUSION	34

LIST OF TABLES

Table 1. Population Served by Clay Roane PSD.....	4
Table 2. Clay Roane PSD Water Treatment Information.....	5
Table 3. Clay Roane PSD Surface Water Sources.....	6
Table 4. Clay Roane PSD Groundwater Sources.....	6
Table 5. Watershed Delineation Information.....	8
Table 6. Protection Team Member and Contact Information.....	10
Table 7. Locally Identified Potential Sources of Significant Contamination.....	13
Table 8. Priority PSSCs or Critical Areas.....	16
Table 9. Priority PSSC Management Strategies.....	17
Table 10. Education and Outreach Implementation Plan.....	22
Table 11. Clay Roane PSD Water Shortage Response Capability.....	25
Table 12. Generator Capacity.....	26
Table 13. Future Water Supply Needs for Clay Roane PSD.....	27
Table 14. Water Loss Information.....	28
Table 15. Early Warning Monitoring System Capabilities.....	29

APPENDICES

- Appendix A. Figures
- Appendix B. Early Warning Monitoring System Forms
- Appendix C. Communication Plan Template
- Appendix D. Single Source Feasibility Study
- Appendix E. Supporting Documentation

SOURCE WATER PROGRAM ACRONYMS

AST	Aboveground Storage Tank
BMP	Best Management Practices
ERP	Emergency Response Plan
GWUDI	Ground Water Under the Direct Influence of Surface Water
LEPC	Local Emergency Planning Committee
OEHS/EED	Office of Environmental Health Services/Environmental Engineering Division
PE	Professional Engineer
PSSCs	Potential Source of Significant Contamination
PWSU	Public Water System Utility
RAIN	River Alert Information Network
RPDC	Regional Planning and Development Council
SDWA	Safe Drinking Water Act
SWAP	Source Water Assessment and Protection
SWAPP	Source Water Assessment and Protection Program
SWP	Source Water Protection
SWPA	Source Water Protection Area
SWPP	Source Water Protection Plan
WARN	Water/Wastewater Agency Response Network
WHPA	Wellhead Protection Area
WHPP	Wellhead Protection Program
WSDA	Watershed Delineation Area
WVBPH	West Virginia Bureau for Public Health
WVDEP	West Virginia Department of Environmental Protection
WVDHHR	West Virginia Department of Health and Human Resources
WVDHSEM	West Virginia Division of Homeland Security and Emergency Management
ZCC	Zone of Critical Concern
ZPC	Zone of Peripheral Concern

1.0 PURPOSE

The goal of the West Virginia Bureau of Public Health (WVBPH) source water assessment and protection (SWAP) program is to prevent degradation of source waters which may preclude present and future uses of drinking water supplies to provide safe water in sufficient quantity to users. The most efficient way to accomplish this goal is to encourage and oversee source water protection on a local level. Many aspects of source water protection may be best addressed by engaging local stakeholders.

The intent of this document is to describe what Clay Roane Public Service District (PSD) has done, is currently doing, and plans to do to protect its source of drinking water. Although this water system treats the water to meet federal and state drinking water standards, conventional treatment does not fully eradicate all potential contaminants and treatment that goes beyond conventional methods is often very expensive. By completing this plan, Clay Roane PSD acknowledges that implementing measures to minimize and mitigate contamination can be a relatively economical way to help ensure the safety of the drinking water.

1.1 WHAT ARE THE BENEFITS OF PREPARING A SOURCE WATER PROTECTION PLAN?

- Fulfilling the requirement for the public water utilities to complete or update their source water protection plan.
- Identifying and prioritizing potential threats to the source of drinking water; and establishing strategies to minimize the threats.
- Planning for emergency response to incidents that compromise the water supply by contamination or depletion, including how the public, state, and local agencies will be informed.
- Planning for future expansion and development, including establishing secondary sources of water.
- Ensuring conditions to provide the safest and highest quality drinking water to customers at the lowest possible cost.
- Providing more opportunities for funding to improve infrastructure, purchase land in the protection area, and other improvements to the intake or source water protection areas.

2.0 BACKGROUND: WV SOURCE WATER ASSESSMENT AND PROTECTION PROGRAM

Since 1974, the federal Safe Drinking Water Act (SDWA) has set minimum standards on the construction, operation, and quality of water provided by public water systems. In 1986, Congress amended the SDWA. A portion of those amendments were designed to protect the source water contribution areas around ground water supply wells. This program eventually became known as the Wellhead Protection Program (WHPP). The purpose of the WHPP is to prevent pollution of the source water supplying the wells.

The Safe Drinking Water Act Amendments of 1996 expanded the concept of wellhead protection to include surface water sources under the umbrella term of Source Water Protection. The amendments encourage states to establish SWAP programs to protect all public drinking water supplies. As part of this initiative states must explain how protection areas for each public water system will be delineated, how potential contaminant sources will be inventoried, and how susceptibility ratings will be established.

In 1999, the WVBPH published the West Virginia Source Water Assessment and Protection Program, which was endorsed by the United States Environmental Protection Agency. Over the next few years, WVBPH staff completed an assessment (i.e., delineation, inventory and susceptibility analysis) for all of West Virginia's public water systems. Each public water system was sent a copy of its assessment report. Information regarding assessment reports for Clay Roane PSD can be found in **Table 1**.

3.0 STATE REGULATORY REQUIREMENTS

On June 6, 2014, §16 1 2 and §16 1 9a of the Code of West Virginia, 1931, was reenacted and amended by adding three new sections, designated §16 1 9c, §16 1 9d and §16-1-9e. The changes to the code outlines specific requirements for public water utilities that draw water from a surface water source or a surface water influenced groundwater source.

Under the amended and new codes, each existing public water utility using surface water or ground water influenced by surface water as a source must have completed or updated a source water protection plan by July 1, 2016, and must continue to update their plan every three years. Existing source water protection plans have been developed for many public water utilities in the past. If available, these plans were reviewed and considered in the development of this updated plan. Any new water system established after July 1, 2016 must submit a source water protection plan before they start to operate. A new plan is also required when there is a significant change in the potential sources of significant contamination (PSSC) within the zone of critical concern (ZCC).

The code also requires that public water utilities include details regarding PSSCs, protection measures, system capacities, contingency plans, and communication plans. Before a plan can be approved, the local health department and public will be invited to contribute information for consideration. In some instances, public water utilities may be asked to conduct independent studies of the source water protection area and specific threats to gain additional information.

4.0 SYSTEM INFORMATION

Clay Roane PSD is classified as a state regulated public utility and operates a community public water system. A community public water system is a system that regularly supplies drinking water from its own sources to at least 15 service connections used by year round residents of the area or regularly serves 25 or more people throughout the entire year. For purposes of this source water protection plan, community public water systems are also referred to as public water utilities. Information on the population served by this utility is presented in **Table 1** below.

Table 1. Population Served by Clay Roane PSD

Administrative office location:	P.O. Box 8 (1100 Elkhurst Road) Procious, WV 25164		
Is the system a public utility, according to the Public Service Commission rule?	Yes; Community Public Water System		
Date of Most Recent Source Water Assessment Report:	November 2002		
Date of Most Recent Source Water Protection Plan:	May 2010		
Population served directly:	900 Total Customers		
Bulk Water Purchaser Systems:	System Name	PWSID Number	Population
	N/A		
Total Population Served by the Utility:	900 Total Customers 2,500 Total Population		
Does the utility have multiple source water protection areas (SWPAs)?	No		
How many SWPAs does the utility have?	1		

Information for this table was taken from the Engineering Study for Contingency Planning prepared by Potesta and Associates, Inc. The complete report is provided as Appendix D.

5.0 WATER TREATMENT AND STORAGE

As required, Clay Roane PSD has assessed their system (e.g., treatment capacity, storage capacity, unaccounted for water, contingency plans) to evaluate their ability to provide drinking water and protect public health. **Table 2** contains information on the water treatment methods and capacity of the utility. Information about the surface sources from which Clay Roane PSD draws water can be found in **Table 3**. If the utility draws water from any groundwater sources to blend with the surface water the information about these ground water sources can be found in **Table 4**.

Table 2. Clay Roane PSD Water Treatment Information

Water Treatment Processes (List All Processes in Order)	Coagulation, Flocculation, Settling, Filtration and Disinfection
Current Treatment Capacity (gal/day)	129,600 GPD
Current Average Production (gal/day)	79,837 GPD
Maximum Quantity Treated and Produced (gal)	137,700 GPD
Minimum Quantity Treated and Produced (gal)	5,000 GPD
Average Hours of Operation	16 hours per day
Maximum Hours of Operation in One Day	24
Minimum Hours of Operation in One Day	1
Number of Storage Tanks Maintained	6
Total Gallons of Treated Water Storage (gal)	480,100 GAL
Total Gallons of Raw Water Storage (gal)	0 GAL

Information for this table was taken from the Engineering Study for Contingency Planning prepared by Potesta and Associates, Inc. The complete report is provided as Appendix D.

Table 3. Clay Roane PSD Surface Water Sources

Intake Name	SDWIS #	Local Name	Describe Intake	Name of Water Source	Date Constructed / Modified	Frequency of Use (Primary/ Backup/ Emergency)	Activity Status (Active/ Inactive)
Raw Water Intake	N/A	N/A	Open end 6" intake pump pipe with screens. Two intakes, one upper and one lower, at middle and at edge of river.	Elk River	N/A	Primary	Active

Information for this table was taken from the Engineering Study for Contingency Planning prepared by Potesta and Associates, Inc. The complete report is provided as Appendix D.

Table 4. Clay Roane PSD Groundwater Sources

Does the utility blend with groundwater?					No				
Well/Spring Name	SDWIS #	Local Name	Date Constructed/ Modified	Completion Report Available (Yes/No)	Well Depth (ft)	Casing Depth (ft)	Grout (Yes/No)	Frequency of Use (Primary/ Backup/ Emergency)	Activity Status (Active/ Inactive)
N/A									

6.0 DELINEATIONS

For surface water systems, delineation is the process used to identify and map the drainage basin that supplies water to a surface water intake. This area is generally referred to as the source water protection area (SWPA). All surface waters are susceptible to contamination because they are exposed at the surface and lack a protective barrier from contamination. Accidental spills, releases, sudden precipitation events that result in overland runoff, or storm sewer discharges can allow pollutants to readily enter the source water and potentially contaminate the drinking water at the intake. The SWPA for surface water is distinguished as a Watershed Delineation Area (WSDA) for planning purposes; and the Zone of Peripheral Concern (ZPC) and Zone of Critical Concern (ZCC) are defined for regulatory purposes.

The WSDA includes the entire watershed area upstream of the intake to the boundary of the State of West Virginia border or a topographic boundary. The ZCC for a public surface water supply is a corridor along streams within the watershed that warrants more detailed scrutiny due to its proximity to the surface water intake and the intake's susceptibility to potential contaminants within that corridor. The ZCC is determined using a mathematical model that accounts for stream flows, gradient and area topography. The length of the ZCC is based on a five-hour time-of-travel of water in the streams to the water intake, plus an additional one-quarter mile below the water intake. The width of the zone of critical concern is 1,000 feet measured horizontally from each bank of the principal stream and 500 feet measured horizontally from each bank of the tributaries draining into the principal stream. Ohio River ZCC delineations are based on ORSANCO guidance and extend 25 miles above the intake and one-quarter mile below the intake. The Ohio River ZCC delineations include 1,320 feet (one-quarter mile) measured from the bank of the main stem of the Ohio River and 500 feet on tributary.

The ZPC for a public surface water supply source and for a public surface water influenced groundwater supply source is a corridor along streams within a watershed that warrants scrutiny due to its proximity to the surface water intake and the intake's susceptibility to potential contaminants within that corridor. The ZPC is determined using a mathematical model that accounts for stream flows, gradient and area topography. The length of the zone of peripheral concern is based on an additional five-hour time-of-travel of water in the streams beyond the perimeter of the zone of critical concern, which creates a protection zone of ten hours above the water intake. The width of the zone of peripheral concern is 1,000 feet measured horizontally from each bank of the principal stream and 500 feet measured horizontally from each bank of the tributaries draining into the principal stream.

For groundwater supplies there are two types of SWPA delineations: 1) wellhead delineations and 2) conjunctive delineations, which are developed for supplies identified as groundwater under the direct influence of surface water, or GWUDIs. A wellhead protection area is determined to be the area contributing to the recharge of the groundwater source (well or spring), within a five year time of travel. A conjunctive delineation combines a wellhead protection area for the hydrogeologic recharge and a connected surface area contributing to the wellhead.

Information and maps of the WSDA, ZCC, ZPC and Wellhead Protection Area for this public water supply were provided to the utility and are attached to this report. See **Appendix A. Figures**. Other information about the WSDA is shown in **Table 5**.

Table 5. Watershed Delineation Information

Size of WSDA (Indicate units)	1,109 square miles
River Watershed Name (8-digit HUC)	Elk River Watershed (05050007)
Size of Zone of Critical Concern (Acres)	11,698.9
Size of Zone of Peripheral Concern (Acres) (Include ZCC area)	35,228.3
Method of Delineation for Groundwater Sources	N/A
Area of Wellhead Protection Area (Acres)	N/A

7.0 PROTECTION TEAM

One important step in preparing a source water protection plan is to organize a source water protection team who will help develop and implement the plan. The legislative rule requires that water utilities make every effort to inform and engage the public, local government, local emergency planners, the local health department and affected residents at all levels of the development of the protection plan. WVBPH recommends that the water utility invite representatives from these organizations to join the protection team, which will ensure that they are given an opportunity to contribute in all aspects of source water protection plan development. Public water utilities should document their efforts to engage representatives and provide an explanation if any local stakeholder is unable to participate. In addition, other local stakeholders may be invited to participate on the team or contribute information to be considered. These individuals may be emergency response personnel, local decision makers, business and industry representatives, land owners (of land in the protection area), and additional concerned citizens.

The administrative contact for Clay Roane PSD is responsible for assembling the protection team and ensuring that members are provided the opportunity to contribute to the development of the plan. The acting members of the Protection Team are listed in **Table 6**.

The role of the protection team members will be to contribute information to the development of the source water protection plan, review draft plans and make recommendations to ensure accuracy and completeness, and when possible contribute to implementation and maintenance of the protection plan. The protection team members are chosen as trusted representatives of the community served by the water utility and may be designated to access confidential data that contains details about the local potential sources of significant contamination. The input of the protection team will be carefully considered by the water utility when making final decisions relative to the documentation and implementation of the source water protection plan.

Clay Roane PSD will be responsible for updating the source water protection plan and rely upon input from the protection team and the public to better inform their decisions. To find out how you can become involved as a participant or contributor, visit the utility website or call the utility phone number, which are provided in **Table 6**.

Table 6. Protection Team Member and Contact Information

Name	Representing	Title	Phone Number	Email
Crystal Hayes	Clay-Roane PSD (Precious District)	General Manager	304-548-5209	clayroanepsdww@frontier.com
Robert Burdette	Clay-Roane PSD (Precious District)	WTP Chief Operator	304-548-5209	
Brian Holcomb	Clay-Roane PSD	Board Chairman	[REDACTED]	
Mike Scott	Clay Volunteer Fire Department	Fire Chief	[REDACTED]	
Heath Cliver	Clay County Health Department	Sanitarian	[REDACTED]	
Stacy King	Clay County Emergency Services	Director	[REDACTED]	
Angie Rosser	WV Rivers Coalition	Executive Director	[REDACTED]	
Date of first protection Team Meeting		May 17, 2016		
Efforts made to inform and engage local stakeholders (public, local government, local emergency planners, local health department, and affected residents) and explain absence of recommended stakeholders:		<p>Protection team meeting was held May 17, 2016, 1:00 pm, Clay City Hall, 956 Main Street, Clay. Meeting included representatives from both Clay Roane PSD and Clay Municipal Water. A joint protection meeting was held because the two systems both have intakes on the Elk River in close proximity to one another.</p> <p>Attendees were: Drema Thomas, Clay Municipal Water, Chief Operator; Dwana Murphy, Clay Municipal Water, Operator; Joe Coleman, Clay Municipal Water, Plant Maintenance and Town Recorder; Crystal Hayes, Clay Roane PSD General Manager; Robert Burdette, Clay Roane PDS Chief Operator; Angie Rosser, West Virginia Rivers Coalition, Executive Director; and John Beckman, Tetra Tech.</p> <p>Discussed Charleston Water Crisis and subsequent new legislation. Mentioned old source water plan developed by Potesta in 2011, and new contingency plan and feasibility study by Potesta in 2015. Reviewed protection team table and updated contact information. Discussed Algae bloom on Sutton Lake in 2014.</p>		

	<p>Reviewed local and regulated PSSC maps and Tables 8 and 9. Reviewed Table 10 for Education and Outreach activities. Discussed generators owned by the system.</p> <p>Discussed need to inform public within 30 minutes of discovering potential contamination of source water. Assigned duties of primary and secondary spokespeople. Updated Police, Fire, and Ambulance contact information. Identified local schools and other sensitive populations. Resolved to hold source water protection public meeting on June 9 concurrent with PSD board meeting. Meeting minutes for protection team meeting are attached in Appendix E.</p>
--	---

8.0 POTENTIAL SIGNIFICANT SOURCES OF SIGNIFICANT CONTAMINATION

Source water protection plans should provide a complete and comprehensive list of the potential sources of significant contamination (PSSC) contained within the ZCC based upon information obtained from the WVBPH, working in cooperation with the West Virginia Department of Environmental Protection (WVDEP) and the West Virginia Division of Homeland Security and Emergency Management (WVDHSEM). A facility or activity is listed as a PSSC if it has the potential to release a contaminant that could potentially impact a nearby public water supply, and it does not necessarily indicate that any release has occurred.

The list of PSSCs located in the SWPA is organized into two types: 1) SWAP PSSCs, and 2) Regulated Data. SWAP PSSCs are those that have been collected and verified by the WVBPH SWAP program during previous field investigations to form source water assessment reports and source water protection plans. Regulated PSSCs are derived from federal and state regulated databases, and may include data from WVDEP, US Environmental Protection Agency, WVDHSEM, and from state data sources.

8.1 CONFIDENTIALITY OF PSSCS

A list of the PSSCs contained within the ZCC should be included in the source water protection plan. However, the exact location, characteristics and approximate quantities of contaminants shall only be made known to one or more designees of the public water utility and maintained in a confidential manner. In the event of a chemical spill, release or other related emergency, information pertaining to the contaminant shall be immediately disseminated to any emergency responders reporting to the site. The designees for Clay Roane PSD are identified in the communication planning section of the source water protection plan.

PSSC data from some agencies (ex., WVDHSEM, WVDEP, etc.) may be restricted due to the sensitive nature of the data. Locational data will be provided to the public water utility. However, to obtain specific details regarding contaminants, (such as information included in Tier II reports), water utilities should contact the local emergency planning commission or agencies, directly. While the maps and lists of the PSSCs and regulated sites are to be maintained in a confidential manner, these data are provided in **Appendix A. Figures** for internal review and planning uses only.

8.2 LOCAL AND REGIONAL PSSCS

For the purposes of this source water protection plan, local PSSCs are those that are identified by local stakeholders in addition to the PSSCs lists distributed by the WVBPH and other agencies. Local stakeholders may identify local PSSCs for two main reasons. The first is that it is possible that threats exist from unregulated sources and land uses that have not already been inventoried and do not appear in regulated databases. For this reason each public water utility should investigate their protection area for local PSSCs. A PSSC inventory should identify all contaminant sources and land uses in the delineated ZCC. The second reason local PSSCs are identified is because public water utilities may consider expanding the PSSC inventory effort outside of the ZCC into the ZPC and WSDA if necessary to properly identify all threats that could impact the drinking water source. As the utility considers threats in the watershed they may consider collaborating with upstream communities to identify and manage regional PSSCs.

When conducting local and regional PSSC inventories, utilities should consider that some sources may be obvious like above ground storage tanks, landfills, livestock confinement areas, highway or railroad right of ways, and sewage treatment facilities. Others are harder to locate like abandoned cesspools, underground tanks, French drains, dry wells, or old dumps and mines.

Clay Roane PSD reviewed intake locations and the delineated SWPAs to verify the existence of PSSCs provided by the WVBPH and identify new PSSCs. If possible, locations of regulated sites within the SWPA were confirmed. Information on any new or updated PSSCs identified by Clay Roane PSD that do not already appear in datasets from the WVBPH can be found in **Table 7**.

Table 7. Locally Identified Potential Sources of Significant Contamination

PSSC Number	Map Code	Site Name	Site Description	Relative Risk Score	Comments
N/A	N/A	Sutton Lake	Blue-green algae blooms can occur in Sutton Lake during extremely hot summer temperatures. During the most recent bloom in 2014, Clay Roane PSD did not receive warning that water being released from Sutton Dam would affect the Elk River downstream until one week after the event. No adverse effects to finished water were observed.	Low	U.S. Army Corps of Engineers can manipulate dam outfall to reduce algae concentrations in water released from the dam.

8.3 PRIORITIZATION OF POTENTIAL THREATS AND MANAGEMENT STRATEGIES

Once the utility has identified local concerns, they must develop a management plan that identifies specific activities that will be pursued by the public water utility in cooperation and concert with the WVBPH, local health departments, local emergency responders, LEPC and other agencies and organizations to protect the source water from contamination.

Depending on the number identified, it may not be feasible to develop management strategies for all of the PSSCs in the SWPA. The identified PSSCs can be prioritized by potential threat to water quality, proximity to the intake(s), and local concern. The highest priority PSSCs can be addressed first in the initial management plan. Lower ranked PSSCs can be addressed in the future as time and resources allow. To assess the threat to the source water, water systems should consider confidential information about each PSSC. This information may be obtained from state or local emergency planning agencies, Tier II reports, facility owner, facility groundwater protection plans, spill prevention response plans, results of field investigations, etc.

In addition to identifying and prioritizing PSSCs within the SWPA, local source water concerns may also focus on critical areas. For the purposes of this source water protection plan, a critical area is defined as an area that is identified by local stakeholders and can lie within or outside of the ZCC. Critical areas may contain one or more PSSCs which would require immediate response to address a potential incident that could impact the source water.

A list of priority PSSCs was selected and ranked by the Clay Roane PSD Protection Team. This list reflects the concerns of this specific utility and may contain PSSCs not previously identified and not within the ZCC or ZPC. **Table 8** contains a description of why each critical area or PSSC is considered a threat and what management strategies the utility is either currently using or could use in the future to address each threat.

9.0 IMPLEMENTATION PLAN FOR MANAGEMENT STRATEGIES

Clay Roane PSD reviewed the recommended strategies listed in their previous source water protection plan, to consider if any of them should be adopted and incorporated in this updated plan. **Table 9** provides a brief statement summarizing the status of the recommended strategies. **Table 9** also lists strategies from a previous plan that are being incorporated in this plan update.

When considering source management strategies and education and outreach strategies, this utility has considered how and when the strategies will be implemented. The initial step in implementation is to establish responsible parties and timelines to implement the strategies. The water utility, working in conjunction with the protection team members, can determine the best process for completing activities within the projected time periods. Additional meetings may be needed during the initial effort to complete activities, after which the protection team should consider meeting annually to review and update the Source Water Protection Plan. A system of regular updates should be included in every implementation plan.

Proposed commitments and schedules may change, but should be well documented and reported to the local stakeholders. If possible, utilities should include cost estimates for strategies to better plan for implementation and possible funding opportunities. Clay Roane PSD has developed an implementation plan for the priority concerns listed in **Table 8**. The responsible team member, timeline, and potential cost of each strategy are presented in **Table 9**. Note: Because timelines may change, future plan updates should describe the status of each strategy and explain the lack of progress.

Table 8. Priority PSSCs or Critical Areas

PSSC or Critical Area	Priority Number	Reason for Concern
State Route 16 and State Route 4	1	Roads parallel Elk River above the intake. Potential fuel or chemical spills resulting from vehicle accidents are a concern.
Sanitary Septic Systems, Home Aeration Units, Wastewater Treatment Systems and Overflows from Larger Sanitary Sewer Systems	2	Discharge from smaller, failing sanitary systems, as well as overflows from larger sanitary sewer system located upstream of intake, can pose a possible contamination threat, including the introduction of fecal coliform into source water. E. coli testing has been problematic in the past.
Oil and Gas Wells (Numerous Regulated Sites)	3	Drilling of gas wells within the SWPA and areas upstream is increasing, including drilling of Marcellus Shale wells. Drilling of some Marcellus Shale wells can produce large volumes of brine water, and can produce water with chemical additives used for fracturing and constituents such as benzene and certain radioactive elements. Uncontrolled spills and releases could introduce contaminants into source water. Some constituents in brine, including bromides, have the potential to increase total trihalomethane formation.
Industry	4	Areas upstream of intake, such as Town of Clay, are relatively heavily developed. Surface water protection practices for local industries may not be known.

Table 9. Priority PSSC Management Strategies

PSSC or Critical Area	Management Activity	Responsible Protection Team Member	Status/Schedule	Comments	Estimated Cost
Previous Plan Status	There were 14 management strategies recommended in the existing plan. One of these strategies have been accomplished. Fourteen of these are ongoing or continue to be a concern. These are incorporated in this plan update and listed below.				
Source Water Protection Area	The utility is required to update the Source Water Protection Plan at least every 3 years and continue to monitor any ongoing or new activities that occur in the watershed.	Clay Roane PSD Protection Team	Ongoing every 3 years. Next update in 2019	-	-
Emergency Response	Communicate regularly with community first responders (Hazmat, police, fire department, etc.), including identifying appropriate contacts and raising awareness for the need to protect drinking water supplies.	PWS Chief Operator / General Manager	Ongoing	Chief operator plans to participate in upcoming county LEPC tabletop emergency drills.	No direct cost. An ongoing annual effort is required.
State Route 16 and State Route 4	1. Continue coordination of emergency response with local first responders, including raising awareness for the need to protect drinking water supplies.	PWS Chief Operator	Ongoing	Chief operator plans to participate in upcoming county LEPC tabletop emergency drills.	No direct cost. An ongoing annual effort is required.
	2. Contact fire department and other first responders on boom availability. If none (or if unsuitable), evaluate purchase of booms for in-stream spill containment.	PWS Chief Operator	As necessary	Contact fire department and other first responders on boom availability. If none (or if unsuitable), then evaluate boom purchase.	Undetermined, but can typically cost up to \$10,000.

Sanitary Septic Systems, Home Aeration Units, Wastewater Treatment Systems and Overflows from Larger Sanitary Sewer Systems	1. Support study and planning of sanitary sewer system extensions and upgrades along Elk River and tributaries upstream of intake to extend service to these areas and eliminate failing septic systems, home aeration units and wastewater treatment systems, and overflows from larger sanitary sewer systems.	Clay-Roane PSD (Procious District) / County Commission	As required.		Undetermined. Supporting extensions may not involve direct cost.
	2. Raise awareness at county commissions for need for source water protection to increase support for proposed sanitary sewer system extensions and upgrades.	PWS Chief Operator / General Manager	As necessary	Utilize map included in this report.	N/A
	3. Evaluate enhanced fecal coliform testing of surface water to better identify sources of fecal coliform contamination, including coordinating efforts with Town of Clay.	PWS Chief Operator / General Manager	As necessary		Enhanced testing costs can range from \$1,000 and up depending on program. WVDHHR grant funds may be available.
Oil and Gas Wells (Numerous Regulated Sites)	1. Review public information on surface water protection practices for oil and gas industry to raise PWS staff awareness of surface water protection practices of oil and gas industry.	PWS Chief Operator / General Manager / PSD Member	As necessary	The West Virginia Department of Environmental Protection retains copies of protection plans that can be obtained through Freedom of Information Act requests.	Minimal (Freedom of Information Act charges, mileage).
	2. Evaluate increased sampling of water quality for parameters (e.g., chlorides, bromides, TDS) associated with oil and gas industry to better assess whether source water quality is being impacted by oil and gas industry, and help develop baseline data of water quality.	PWS Chief Operator / General Manager	As necessary		Enhanced testing costs can range from \$1,000 and up depending on program. WVDHHR grant funds may be available.

	3. Evaluate installing into source water, upstream of intake, monitoring equipment to provide early warning of possible brine or other spills into source water and help develop water quality data of source water.	PWS Chief Operator / General Manager	As necessary	Contact WVDHHR Source Water Assessment and Protection Program for questions. Note: River Alert Information Network (RAIN) is an early warning system, which can monitor source water and detect spills. While it is a Pennsylvania organization, it has been promoted for expansion into West Virginia.	Preliminary cost of \$9,200 for remote TDS (conductivity) meter, not including "soft costs," land easements, utility extensions, etc. Also, annual service cost estimated at \$750 per year. WVDHHR grant funds may be available.
	4. Maintain contact with other neighboring public water systems, to receive input on effects of anticipated Marcellus Shale and gas well drilling, and track status of regulations through such organizations as WVDHHR and West Virginia Rural Water Association.	PWS Chief Operator / General Manager	Ongoing.	Public water systems to the north (e.g., West Union) have taken an intensive interest in proposed gas well development of Marcellus Shale.	Minimal. Possible cost for registration at seminars/conferences, mileage, lodging, etc.
	5. If parameters associated with oil and gas industry become problematic to water quality, consider symposium for local oil and gas industry to raise awareness of source water protection and review regulatory requirements.	PWS Chief Operator / General Manager / County Commission	Undetermined	If deemed warranted based on results of Items above. If watershed group identified, they may be willing to assist effort.	
Industry	1. Review public information on surface water protection practices, including results of sampling required by NPDES permit for industry to raise PWS staff awareness of surface water protection plan practices industries on the watershed.	PWS Chief Operator / General Manager / PSD Member	As necessary	The West Virginia Department of Environmental Protection retains copies of protection plans that can be obtained through Freedom of Information Act requests.	Minimal (Freedom of Information Act charges, mileage).

	2. Evaluate purchase of booms for in-stream spill containment.	PWS Chief Operator / General Manager	As necessary	Coordinate with fire department.	Undetermined, but can typically cost up to \$10,000.
	3. Evaluate what authority exists at county government regarding approval over development that could be a higher risk to surface water resources.	PWS General Manager / County Commission Member	Undetermined		Depends on consultant and/or legal fees, and size and scope of effort.
Yearly Windshield Survey	The utility's staff will perform a yearly "windshield survey" of the zone of critical concern. They will note changes in land use, water quality, and other developments that may have occurred since the previous year's survey. These changes will be documented and reflected in future source water protection plan updates.	Water utility staff	Yearly, next survey in 2017	-	Minimal cost associated with staff time
Regular Coordination with Emergency Managers	Local emergency planners have access to confidential chemical contaminant information in Tier II reports from facilities in the SWPA. The utility should coordinate with the local emergency planners to gain an understanding of potential contaminants to better prepare for a spill event. Utility staff will continue to communicate with these emergency services groups on a regular basis, especially when there is not an ongoing emergency. They will invite the local emergency planners to meet yearly as part of the Source Water Protection Team.	Water utility staff emergency personnel	Engage local emergency planners immediately and communicate on a regular basis.	-	Minimal cost associated with staff time
Yearly Source Water Protection Team Meetings	The utility's staff will invite the protection team to meet on a yearly basis to discuss any changes that might have occurred within the watershed or to find replacements for members who can no longer participate.	Source Water Protection Team	Yearly, next meeting in 2017	-	Minimal cost associated with staff time

10.0 EDUCATION AND OUTREACH STRATEGIES

The goal of education and outreach is to raise awareness of the need to protect drinking water supplies and build support for implementation strategies. Education and outreach activities will also ensure that affected citizens and other local stakeholders are kept informed and provided an opportunity to contribute to the development of the source water protection plan. Clay Roane PSD has created an Education and Outreach plan that describes activities it has either already implemented or could implement in the future to keep the local community involved in protecting their source of drinking water. This information can be found in **Table 10**.

Table 10. Education and Outreach Implementation Plan

Education and Outreach Strategy	Description of Activity	Responsible Protection Team Member	Status/Schedule	Comments	Estimated Cost
Public Meeting	<p>Clay Roane PSD held a source water protection public meeting on June 9, 2016, 6:30 pm, at the PSD office/water plant in Procious. Public meeting was held concurrently with regularly scheduled PSD board meeting. Meeting was open to the public. Meeting was advertised in the newspaper and with posted advertisements at the PSD office a week before. Meeting minutes are attached in Appendix E.</p> <p>Reviewed source water protection timeline. Discussed Charleston Water Crisis of 2014 and reasons for new source water protection legislation. Discussed update to Clay Roane PSD's 2010 plan, and incorporation of Potesta's contingency/feasibility study. Reviewed plan table of contents and sections.</p> <p>Summarized potential significant sources. Summarized contingency plan alternatives. Discussed 30 minute public notification requirement. Noted Communication Plan in Appendix C with emergency contact information. Reviewed designated spokespeople for Clay Roane PSD.</p>	Mayor/Town Council/Operator	As necessary	Clay Roane PSD may have future public meetings to continue to inform the public of important source water issues.	Minimal. Staff time to attend meetings.

Consumer Confidence Report	Include information on source water protection plan in CCR.	PWS Chief Operator / General Manager	Annually.	The utility publishes a Consumer Confidence Report (CCR) annually, as required by the Safe Drinking Water Act, which is printed in the local newspaper. Information is included in the CCR about the source of drinking water.	Minimal.
	Include information on pharmaceuticals and how to properly dispose of them in CCR.	PWS Chief Operator / General Manager	Ongoing	Due to recent heightened concerns about the effects of pharmaceuticals in surface water bodies, the utility will also include in the 2011 CCR information about pharmaceuticals and how to properly dispose of them. Text may be included annually or on a periodic basis, to be decided.	Minimal.
Outreach Brochure	Educational Brochure (Visit http://www.yourwateryourdecision.org for a brochure building tool that can save effort. This brochure building tool was prepared by the Source Water Collaborative, a partnership between local, state and federal drinking water organizations and regulatory entities including USEPA.)	-	-	-	-
School Curricula	Work with the school system to incorporate source water activities into the school curricula. One example of school curricula is Project WET. For more information regarding free workshops to educate area teachers on	PWS operator and staff	If invited to participate in classroom workshop	Can provide websites with free education materials to promote source water protection and conservation. Also operator may visit school.	Minimal costs. Would require time to coordinate with teachers

	<p>Project WET, visit http://www.dep.wv.gov/WWE/getinvolved/WET/Pages/default.aspx, or contact the WVDEP at 304-926-0495.</p> <p>In addition, the USEPA offers free educational materials for teachers and students, including classroom lessons, fact sheets, and interactive games and activities, for grades K-12. These materials can be accessed at the following websites.</p> <p>For general source water protection: http://www.epa.gov/safewater/kids/index.html.</p> <p>For water conservation: http://www.epa.gov/watersense/resources/educational_materials.html</p> <p>Similar protection and conservation related resources can be found at the Groundwater Foundation website; http://www.groundwater.org/kc/kc.html</p>				<p>or visit classroom</p>
--	--	--	--	--	---------------------------

11.0 CONTINGENCY PLAN

The goal of contingency planning is to identify and document how the utility will prepare for and respond to any drinking water shortages or emergencies that may occur due to short and long term water interruption, or incidents of spill or contamination. During contingency planning, utilities should examine their capacity to protect their intake, treatment, and distribution system from contamination. They should also review their ability to use alternative sources and minimize water loss, as well as their ability to operate during power outages. In addition, utilities should report the feasibility of establishing an early warning monitoring system and meeting future water demands.

Isolating or diverting any possible contaminant from the intake for a public water system is an important strategy in the event of an emergency. One commonly used method of diverting contaminants from an intake is establishing booms around the intake. This can be effective, but only for contaminants that float on the surface of the water. Alternatively, utilities can choose to pump floating contaminants from the water or chemically neutralize the contaminant before it enters the treatment facility.

Public utilities using surface sources should be able to close the intake by one means or another. However, depending upon the system, methods for doing so could vary greatly and include closing valves, lowering hatches or gates, raising the intake piping out of the water, or shutting down pumps. Systems should have plans in place in advance as to the best method to protect the intake and treatment facility. Utilities may benefit from turning off pumps and, if possible, closing the intake opening to prevent contaminants from entering the piping leading to the pumps. Utilities should also have a plan in place to sample raw water to identify the movement of a contaminant plume and allow for maximum pumping time before shutting down an intake (See Early Warning Monitoring System). The amount of time that an intake can remain closed depends on the water infrastructure and should be determined by the utility before an emergency occurs. The longer an intake can remain closed in such a case, the better.

Raw and treated water storage capacity also becomes extremely important in the event of such an emergency. Storage capacity can directly determine how effectively a water system can respond to a contamination event and how long an intake can remain closed. Information regarding the water shortage response capability of Clay Roane PSD is provided in **Table 11**.

11.1 RESPONSE NETWORKS AND COMMUNICATION

Statewide initiatives for emergency response, including source water related incidents, are being developed. These include the West Virginia Water/Wastewater Agency Response Network (WV WARN, see <http://www.wvwarn.org/>) and the Rural Water Association Emergency Response Team (see <http://www.wvrwa.org/>). Clay Roane PSD has analyzed its ability to effectively respond to emergencies and this information is also provided in **Table 11**.

Table 11. Clay Roane PSD Water Shortage Response Capability

Can the utility isolate or divert contamination from the intake or groundwater supply?	Yes; dependent on contamination extent
Describe the utility’s capability to isolate or divert potential contaminants:	The raw water intake is in the middle of the Elk River. There is a lower and upper intake on one structure so Clay Roane PSD has some flexibility to draw water from different water levels.
Can the utility switch to an alternative water source or intake that can supply full capacity at any time?	No
Describe in detail the utility’s capability to switch to an alternative source:	N/A

Can the utility close the water intake to prevent contamination from entering the water supply?	Yes
How long can the intake stay closed?	48 hours (with treated water storage at capacity) 24 hours (with treated water storage at half capacity)
Describe the process to close the intake:	Manually closing valve
Describe the treated water storage capacity of the water system:	The utility has six storage tanks available for treated water with a total capacity of 480,100 gallons.
Is the utility a member of WVRWA Emergency Response Team?	Yes
Is the utility a member of WV-WARN?	Yes
List any other mutual aid agreements to provide or receive assistance in the event of an emergency:	Mutual aid agreement with Clay County Commission.

Information for this table was taken from the Engineering Study for Contingency Planning prepared by Potesta and Associates, Inc. The complete report is provided as Appendix D. Time the intake can stay closed was updated with information gathered at the May 17, 2016 source water protection team meeting.

11.2 OPERATION DURING LOSS OF POWER

Clay Roane PSD analyzed its ability to operate effectively during a loss of power. This involved ensuring a means to supply water through treatment, storage, and distribution without creating a public health emergency. Information regarding the utility’s capacity for operation during power outages is summarized in **Table 12**.

Table 12. Generator Capacity

What is the type and capacity of the generator needed to operate during a loss of power?	System owns several generators, including :Caterpillar (mobile) Generator Model D60-4, Volts 208/120, 3 phase, 60 kW Kohler (stationary) Generator Model 100R0101, Volts 120/240, 3 phase, 90 kW (temporarily out of service) 60 kW and 12kW portable generators also available.
Can the utility connect to generator at intake/wellhead? If yes, select a scenario that best describes system.	No
Can the utility connect to generator at treatment facility? If yes, select a scenario that best describes system.	Yes
Can the utility connect to a generator in distribution system? If yes, select a scenario that best describes system.	Yes; generators can be connected to all booster stations in distribution system.

Does the utility have adequate fuel on hand for the generator?		Yes	
What is your on-hand fuel storage and how long will it last operating at full capacity?		Gallons	Hours
		400	96
Provide a list of suppliers that could provide generators and fuel in the event of an emergency:	Supplier		Phone Number
	Generator	N/A	
	Generator		
	Fuel	N/A	
	Fuel		
Does the utility test the generator(s) periodically?		Once per week	
Does the utility routinely maintain the generator?		Yes; system has a service contract with Caterpillar	
If no scenario describing the ability to connect to generator matches the utility's system or if utility does not have ability to connect to a generator, describe plans to respond to power outages:		N/A	

Information for this table was taken from the Engineering Study for Contingency Planning prepared by Potesta and Associates, Inc. The complete report is provided as Appendix D. On-hand fuel storage was updated with information gathered at the May 17, 2016 source water protection team meeting.

11.3 FUTURE WATER SUPPLY NEEDS

When planning for potential emergencies and developing contingency plans, a utility needs to not only consider their current demands for treated water but also account for likely future needs. This could mean expanding current intake sources or developing new ones in the near future. This can be an expensive and time consuming process, and any water utility should take this into account when determining emergency preparedness. Clay Roane PSD has analyzed its ability to meet future water demands at current capacity, and this information is included in **Table 13**.

Table 13. Future Water Supply Needs for Clay Roane PSD

Is the utility able to meet water demands with the current production capacity over the next 5 years? If so, explain how you plan to do so.	Yes; the local population has experienced a slight decline in the past decade and the utility plans to meet any unexpected increases with existing mode of operation (i.e. producing and purchasing water). System has recently installed a new water tank and plans to add 3 new commercial customers at the industrial park.
--	--

If not, describe the circumstances and plans to increase production capacity:	N/A
--	-----

Information for this table was taken from the Engineering Study for Contingency Planning prepared by Potesta and Associates, Inc. The complete report is provided as Appendix D

11.4 WATER LOSS CALCULATION

In any public water system there is a certain percentage of the total treated water that does not reach the customer. Some of this water is used in treatment plant processes such as back washing filters or flushing piping, but there is usually at least a small percentage that goes unaccounted for. To measure and report on this unaccounted for water, a public utility must use the method described in the Public Service Commission's rule, *Rules for the Government of Water Utilities*, 150CSR7, section 5.6. The rule defines unaccounted for water as the volume of water introduced into the distribution system less all metered usage and all known non-metered usage which can be estimated with reasonable accuracy.

To further clarify, metered usages are most often those that are distributed to customers. Non-metered usages that are being estimated include usage by fire departments for fires or training, un-metered bulk sells, flushing to maintain the distribution system, and water used for backwashing filters and cleaning settling basins. By totaling the known metered and non-metered uses the utility calculates unaccounted for water. Note: To complete annual reports submitted to the PSC, utilities typically account for known water main breaks by estimating the amount of water lost. However, for the purposes of the source water protection plan, any water lost due to leaks, even if the system is aware of how much water is lost at a main break, is not considered a use. Water lost through leaks and main breaks cannot be controlled during a water shortages or other emergencies and should be included in the calculation of percentage of water loss for purposes of the source water protection plan. The data in **Table 14** is taken from the most recently submitted Clay Roane PSD PSC Annual Report.

Table 14. Water Loss Information

Total Water Pumped (gal)		26,230,000
Total Water Purchased (gal)		25,922,000
Total Water Pumped and Purchased (gal)		52,152,000
Water Loss Accounted for Except Main Leaks (gal)	Mains, Plants, Filters, Flushing, etc.	1,190,000
	Fire Department	141,000
	Back Washing	0
	Blowing Settling Basins	0
Total Water Loss Accounted For Except Main Leaks (gal)		1,331,000
Water Sold- Total Gallons (gal)		29,149,000
Unaccounted For Lost Water (gal)		11,483,000

Water lost from main leaks (gal)	10,189,000
Total gallons of Unaccounted for Lost Water and Water Lost from Main Leaks (gal)	21,672,000
Total Percent Unaccounted For Water and Water Lost from Main Leaks (gal)	42%
If total percentage of Unaccounted for Water is greater than 15%, please describe any measures that could be taken to correct this problem:	Clay Roane PSD staff fixes leaks as they identify them and replace meters to reduce water loss. There is no active leak detection program.

Information for this table was taken from the Engineering Study for Contingency Planning prepared by Potesta and Associates, Inc. The complete report is provided as Appendix D.

11.5 EARLY WARNING MONITORING SYSTEM

Public water utilities are required to provide an examination of the technical and economic feasibility of implementing an early warning monitoring system. Implementing an early warning monitoring system may be approached in different ways depending upon the water utility’s resources and threats to the source water. A utility may install a continuous monitoring system that will provide real time information regarding water quality conditions. This would require utilities to analyze the data to establish what condition is indicative of a contamination event. Continuous monitoring will provide results for a predetermined set of parameters. The more parameters that are being monitored, the more sophisticated the monitoring equipment will need to be. When establishing a continuous monitoring system, the utility should consider the logistics of placing and maintaining the equipment, and receiving output data from the equipment.

Alternately, or in addition, a utility may also pull periodic grab samples on a regular basis, or in case of a reported incident. The grab samples may be analyzed for specific contaminants. A utility should examine their PSSCs to determine what chemical contaminants could pose a threat to the water source. If possible, the utility should plan in advance how those contaminants will be detected. Consideration should be given to where samples will be collected, the preservations and hold times for samples, available laboratories to analyze samples, and costs associated with the sampling event. Regardless of the type of monitoring (continuous or grab), utilities should collect samples for their source throughout the year to better understand the baseline water quality conditions and natural seasonal fluctuations. Establishing a baseline will help determine if changes in the water quality are indicative of a contamination event and inform the needed response.

Every utility should establish a system or process for receiving or detecting chemical threats with sufficient time to respond to protect the treatment facility and public health. All approaches to receiving and responding to an early warning should incorporate communication with facility owners and operators that pose a threat to the water quality, with state and local emergency response agencies, with surrounding water utilities, and with the public. Communication plays an important role in knowing how to interpret data and how to respond.

Clay Roane PSD has analyzed its ability to monitor for and detect potential contaminants that could impact its source water. Information regarding this utility’s early warning monitoring system capabilities is provided in **Table 15** and in **Appendix B**.

Table 15. Early Warning Monitoring System Capabilities

Does your system currently receive spill notifications from a state agency, neighboring water system, local emergency responders, or other facilities? If yes, from whom do you receive notices?	Yes; the system would receive spill reports from the WVDHHR.
---	--

Are you aware of any facilities, land uses, or critical areas within your protection areas where chemical contaminants could be released or spilled?		Yes
Are you prepared to detect potential contaminants if notified of a spill?		Yes
List laboratories (and contact information) on whom you would rely to analyze water samples in case of a reported spill.	Laboratories	
	Name	Contact
	REI Consultants	(304) 255-2500
	WV Office of Lab Services	(304) 558-3530
Do you have an understanding of baseline or normal conditions for your source water quality that accounts for seasonal fluctuations?		Yes
Does your utility currently monitor raw water (through continuous monitoring or periodic grab samples) at the surface water intake or from a groundwater source on a regular basis?		Yes
Provide or estimate the capital and O&M costs for your current or proposed early warning system or upgraded system.	Monitoring System	Hach sc1000 (B-2)
	Capital	\$ 35,000
	Yearly O & M	-
Do you serve more than 100,000 customers? If so, please describe the methods you use to monitor at the same technical levels utilized by ORSANCO.		No

Information for this table was taken from the Engineering Study for Contingency Planning prepared by Potesta and Associates, Inc. The complete report is provided as Appendix D.

12.0 SINGLE SOURCE FEASIBILITY STUDY

If a public utility's water treatment plant is supplied by a single-source intake in a surface water source or a surface water influenced source of supply, the submitted source water protection plan must also include an examination and analysis of the technical and economic feasibility of alternative sources of water to provide continued safe and reliable public water service in the event that its primary source of supply is detrimentally affected by contamination, release, spill event or other reason. These alternatives may include a secondary intake, two days of additional raw or treated water storage, an interconnection with neighboring systems, or other options identified on a local level. Note: a suitable secondary intake would be required to draw water supplies from a substantially different location or water source.

To accomplish this requirement, utilities should examine all existing or possible alternatives and rank them by their technical, economic, and environmental feasibility. To have a consistent and complete method for ranking alternatives, WVBPB has developed a feasibility study guide. The guide provides several criteria to consider for each category, organized in a Feasibility Study Matrix. By completing the Feasibility Study Matrix, Clay Roane PSD has demonstrated the process used to examine the feasibility of each alternative and document scores that compare the alternatives. The Feasibility Study matrix and summary of the results are presented in an alternatives feasibility study attached as **Appendix D**.

13.0 COMMUNICATION PLAN

Clay Roane PSD has also developed a Communication Plan that documents the manner in which the public water utility, working in concert with state and local emergency response agencies, shall notify the local health agencies and the public of the initial spill or contamination event and provide updated information related to any contamination or impairment of the system's drinking water supply. The initial notification to the public will occur in any event no later than thirty minutes after the public water system becomes aware of the spill, release, or potential contamination of the public water system. A copy of the source water protection plan and the Communication Plan has been provided to the local fire department. Clay Roane PSD will update the Communication Plan as needed to ensure contact information is up to date.

Procedures should be in place to effectively react to the kinds of catastrophic spills that can reasonably be predicted at the source location or within the SWPA. The chain-of-command, notification procedures and response actions should be known by all water system employees.

The WVBPH has developed a recommended communication plan template that provides a tiered incident communication process to provide a universal system of alert levels to utilities and water system managers. The comprehensive Communication Plan for Clay Roane PSD is attached as **Appendix C** for internal review and planning purposes only.

The West Virginia Department of Environmental Protection is capable of providing expertise and assistance related to prevention, containment, and clean-up of chemical spills. The West Virginia Department of Environmental Protection Emergency Response 24-hour Phone is 1-800-642-3074. The West Virginia Department of Environmental Protection also operates an upstream distance estimator that can be used to determine the distance from a spill site to the closest public water supply surface water intake.

14.0 EMERGENCY RESPONSE SHORT FORM

A public water utility must be prepared for any number of emergency scenarios and events that would require immediate response. It is imperative that information about key contacts, emergency services, and downstream water systems be posted and readily available in the event of an emergency. Elements of this source water protection plan, such as the contingency planning and communication plan, may contain similar information to the utility's emergency response plan. However, the emergency response plan is to be kept confidential and is not included in this source water protection plan. An Emergency Short Form is included in **Appendix C** to support the Communicate Plan by providing quick access to important information about emergency response and are to be used for internal review and planning purposes only.

15.0 CONCLUSION

This report represents a detailed explanation of the required elements of Clay Roane PSD's Source Water Protection Plan. Any supporting documentation or other materials that the utility considers relevant to their plan can be found in **Appendix E**.

This source water protection plan is intended to help prepare community public water systems all over West Virginia to properly handle any emergencies that might compromise the quality of the system's source water supply. It is imperative that this plan is updated as often as necessary to reflect the changing circumstances within the water system. The protection team should continue to meet regularly and continue to engage the public whenever possible. Communities taking local responsibility for the quality of their source water is the most effective way to prevent contamination and protect a water system against contaminated drinking water. Community cooperation, sufficient preparation, and accurate monitoring are all critical components of this source water protection plan, and a multi-faceted approach is the only way to ensure that a system is as protected as possible against source water degradation.

APPENDIX A. FIGURES

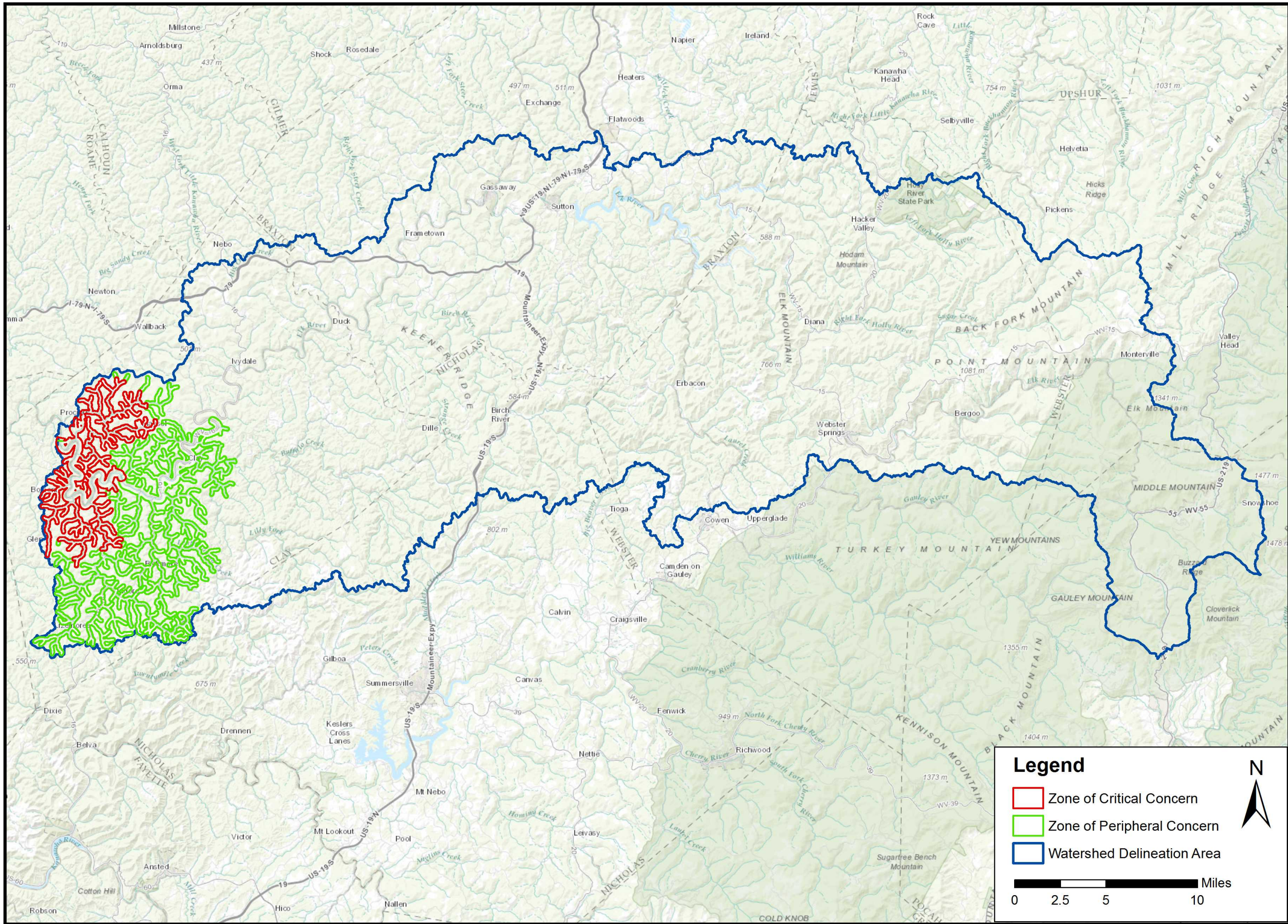

Zone of Critical Concern,
Zone of Peripheral Concern,
and Watershed Delineation Area

CREATED BY: JAW DATE: 2/18/2016

Clay Roane PSD
PWSID: WV3300806
Source Water Protection Plan

Legend

- Zone of Critical Concern
- Zone of Peripheral Concern
- Watershed Delineation Area

0 2.5 5 10 Miles



TETRA TECH
803 Quarrier Street, Suite 400
Charleston, WV 25301

List of Locally Identified PSSCs

PCS No.	Site Name	Site Description	Comments
1	Wells: Injection	Operating pump/well	1 AST, sheen on water in secondary containment
2	Auto repair shops	Auto repair/equipment storage	refuse, parts and containers around site
3	Permitted Discharge Pipe (outfall)	Discharge Pipe	PVC pipe from shed to river, junk cars around house, general trash
4	Auto repair shops	Holcomb's Auto Repair	Auto repair

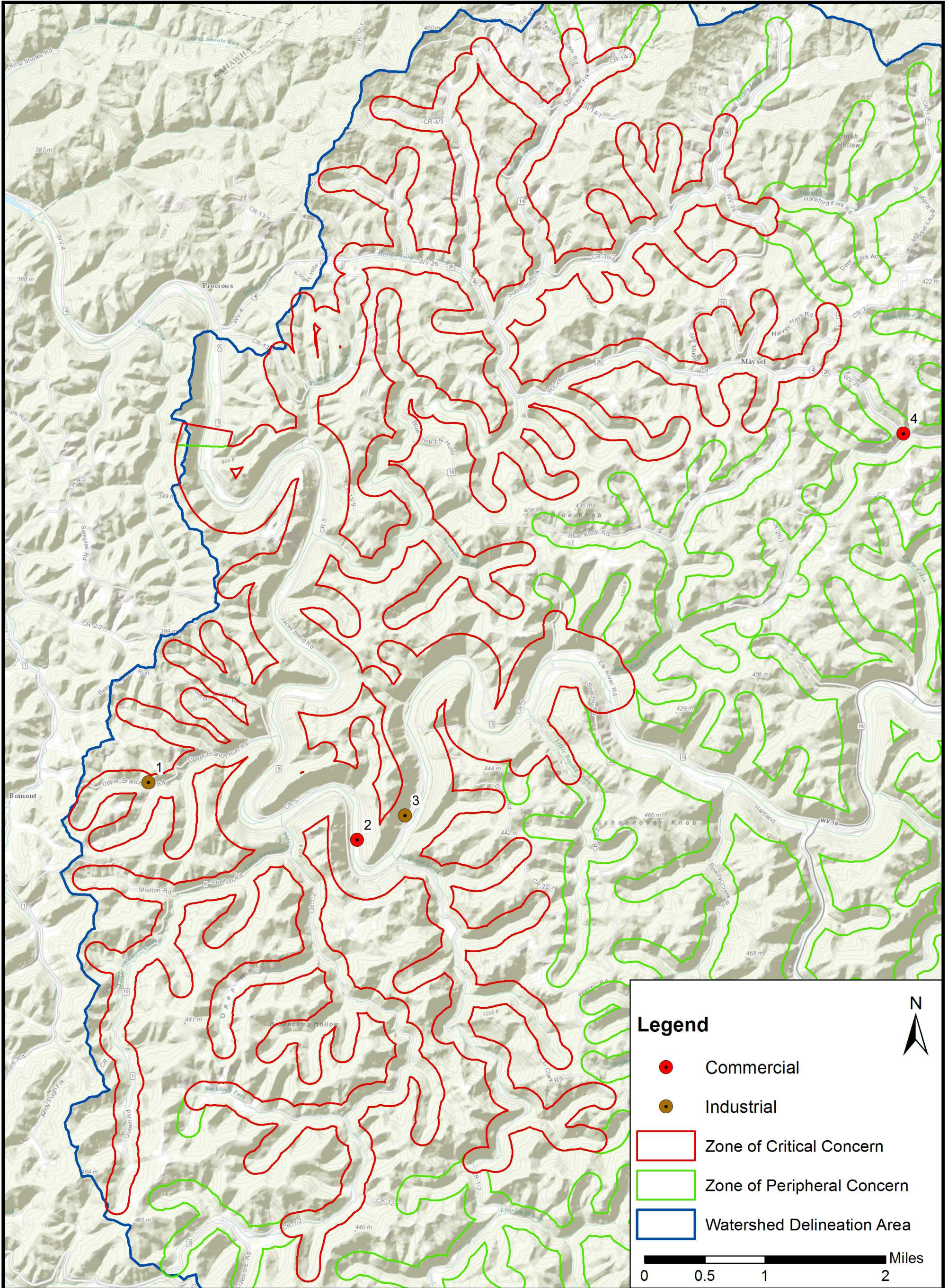

Legend

- Commercial
- Industrial
- Zone of Critical Concern
- Zone of Peripheral Concern
- Watershed Delineation Area

N
↑

0 0.5 1 2 Miles

List of Regulated PSSCs

Regulated No.	Site Name	Site Description	Regulation ID	Comments
R1	* Abandoned Mine Lands	Dorfee Refuse	WV002064	none
R2	Abandoned Mine Lands	Blue Knob Complex	WV002063	none
R3	Abandoned Mine Lands	Blue Knob Complex	WV002063	none
R4	Abandoned Mine Lands	Hartland Tipple	WV002056	none
R5	Abandoned Mine Lands	Clay I & II	WV000396	none
R6	Abandoned Mine Lands	Clay I & II	WV000396	none
R7	Bond Forfeiture Site	Eastern Resources	UO-576	none
R8	Bond Forfeiture Site	Testa Coal Co.	U-79-84	WD 44 - Reclamation Process Complete
R9	NPDES Outlet	H.E. White Elementary School (Clay Co. BOE)	0368-01-015-003	5W32 - Septic Systems(Drain Field Disposal Mthd)
R10	NPDES Outlet	Joshua & Rebecca King	WVG414572-001	Home Aeration Unit General
R11	NPDES Outlet	David F Odom	WVG414507-001	Home Aeration Unit General
R12	NPDES Outlet	Sizemore Trailer Park	WVG550427-001	Sewage General
R13	NPDES Outlet	Anderson Heights/Maysel Manor Apts	WVG550276-001	Sewage General
R14	NPDES Outlet	Risen Lord Catholic Church	WVG413097-001	Home Aeration Unit General
R15	NPDES Outlet	Crossroads Best Restaurant (Carol Holcomb)	0588-03-015-001	5W32 - Septic Systems(Drain Field Disposal Mthd)
R16	NPDES Outlet	WVDOT-Maysel Storage Lot	WVG980072-001	WV DOH+MUN
R17	NPDES Outlet	WVDOT-Maysel Storage Lot	WVG980072-002	WV DOH+MUN
R18	NPDES Outlet	Bullard's Exxon & Quick Stop (Mildred Bullard)	0587-03-015-001	5W32 - Septic Systems(Drain Field Disposal Mthd)
R19	NPDES Outlet	Joes Car Wash	WVG990112-001	Car Wash (GP)
R19	NPDES Outlet	Clay County Park	WVG551102-001	Sewage General
R20	NPDES Outlet	Pierson Lumber Co	WVG610154-001	Storm Water Industrial (GP)

Regulated No.	Site Name	Site Description	Regulation ID	Comments
R21	NPDES Outlet	Pierson Lumber Co	WVG610154-002	Storm Water Industrial (GP)
R22	NPDES Outlet	Pierson Lumber Co	WVG610154-003	Storm Water Industrial (GP)
R23	NPDES Outlet	Pierson Lumber Co	WVG610245-001	Storm Water Industrial (GP)
R24	NPDES Outlet	Pierson Lumber Co	WVG610245-002	Storm Water Industrial (GP)
R25	NPDES Outlet	Pierson Lumber Co	WVG610245-003	Storm Water Industrial (GP)
R26	NPDES Outlet	Pierson Lumber Co	WVG610245-004	Storm Water Industrial (GP)
R27	NPDES Outlet	Pierson Lumber Co	WVG610245-005	Storm Water Industrial (GP)
R28	NPDES Outlet	Pierson Lumber Co	WVG610245-006	Storm Water Industrial (GP)
R29	NPDES Outlet	Pierson Lumber Co	WVG610245-007	Storm Water Industrial (GP)
R30	NPDES Outlet	Myrtle Laxton	WVG411125-001	Home Aeration Unit General
R31	NPDES Outlet	Clay Sanitation Plant	WV0022055-001	Ind POTW
R32	NPDES Outlet	Clay Sanitation Plant	WV0022055-S01	Ind POTW Sludge
R34	LUST Site	Hartland Superette	0807878 99-032	none
R35	LUST Site	Bullard's Exxon & Quick Stop	0800799 93-335	Cleanup complete 10/21/2011

*Abandoned mine lands were labeled if identifying information was available. In areas with multiple features all related to one abandoned mine operation, one label may identify multiple features in its vicinity.

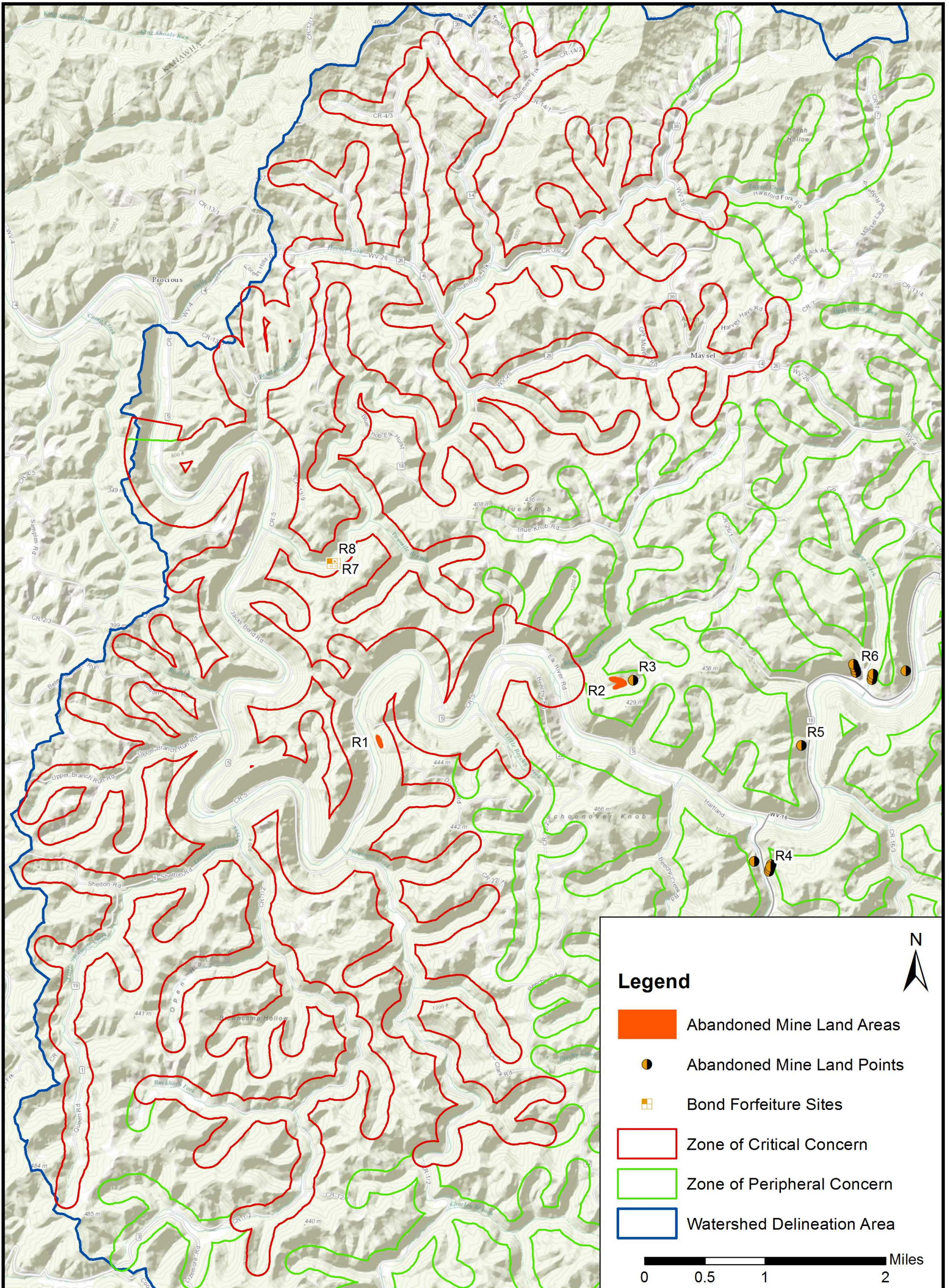

List of Above Ground Storage Tank Regulated PSSCs

Regulated No.	Site Name	Site Description	Regulation ID	Comments
R36	Above Ground Storage Tank	Town of Clay Waste Water Treatment Plant	008-00000533	[REDACTED]
R37	Above Ground Storage Tank	Pierson Lumber Company, Inc.	008-00000539	[REDACTED]

Above ground storage tanks were prioritized for labeling if they were located inside or around the zone of critical concern and contained fuel or toxic chemicals, but were not small crude oil and brine tanks associated with oil/gas production.



TETRA TECH
803 Quarrier Street, Suite 400
Charleston, WV 25301

Clay Roane PSD
PWSID: WV3300806

Source Water Protection Plan

Above Ground Storage Tank
Regulated PSSCs

CREATED BY: JAW

DATE: 2/18/2016

APPENDIX B. EARLY WARNING MONITORING SYSTEM FORMS

Select and Attach the Appropriate Form for Your System

Form A-Complete if you currently have an early warning monitoring system installed for a surface water source

Form B-If you do not currently have an early warning monitoring system installed for a surface water intake or are planning to upgrade or replace your current system, complete this form.

Form C-Complete if you currently have an early warning monitoring system for a groundwater source.

Form D- If you do not currently have an early warning monitoring system installed for a groundwater source or are planning to upgrade or replace your current system, complete this form.

Note: You may need to fill out and attach more than one form to your Protection Plan, depending on your current situation.

Appendix B-Form B**Proposed Early Warning Monitoring System Worksheet- Surface Water Source****Describe the type of early warning detection equipment that could be installed, including the design.**

The early warning detection equipment that could be installed includes a level controller, display module, back panel, level & trough (see cost estimate by Hach Company in Appendix D, "Supporting Documentation") along with conductivity, oil-in-water, ORP, and pH sensors.

Where would the equipment be located?

Early warning monitoring systems would be located on the raw water intake line where Elk River surface water would enter the laboratory in the water treatment facility, or upstream of the raw water intake on the Elk River.

What would the maintenance plan for the monitoring equipment entail?

The proposed maintenance plan for the monitoring equipment shall consist of annual cleaning and/or exchanging of the probe(s) for the controller. Periodic calibration of the unit may also be required.

Describe the proposed sampling plan at the monitoring site.

Sampling of water quality data occurs every fifteen (15) minutes. Clay Roane PSD would need to retrieve data from the "History" of the controller data collector twice per month.

Describe the proposed procedures for data management and analysis.

Data management for the early warning monitoring system consists of data points (up to 500 points or approximately six months per probe) being recorded in the "History" of the controller data collector. To access the "History", the probe has to be plugged into the controller. Data is able to be removed via USB or through a local SCADA system.

APPENDIX C. COMMUNICATION PLAN TEMPLATE

Clay Roane PSD

PWSID: WV3300806 District: Saint Albans, District 2

Certified Operator: Robert Burdette

Contact Phone Number: 304-548-5209

Contact Email Address: _____

Plan Developed On: June 2016 Plan Update: _____

ACKNOWLEDGMENTS:

This plan was developed by Clay Roane PSD to meet certain requirements of the Source Water and Assessment Protection Program (SWAPP) and the Wellhead Protection Program (WHPP) for the State of West Virginia, as directed by the federal Safe Drinking Water Act (SDWA) and state laws and regulations.

TABLE OF CONTENTS

INTRODUCTION.....	1
TIERS REPORTING SYSTEM	1
COMMUNICATION TEAM.....	2
COMMUNICATION TEAM DUTIES	2
INCIDENT / EVENT COMMUNICATION PROCEDURE	3
TIERS FLOW CHART	5
EMERGENCY SHORT FORMS	6
EMERGENCY CONTACT INFORMATION.....	9
PRESS RELEASE ATTACHMENTS	10

INTRODUCTION

Legislative Rule 64CSR3 requires public water systems to develop a Communication Plan that documents how public water suppliers, working in concert with state and local emergency response agencies, shall notify state and local health agencies and the public in the event of a spill or contamination event that poses a potential threat to public health and safety. The plan must indicate how the public water supplier will provide updated information, with an initial notification to the public to occur no later than thirty minutes after the supplier becomes aware that the spill, release or potential contamination of the public water system poses a potential threat to public health and safety.

The public water system has responsibility to communicate to the public, as well as to state and local health agencies. This plan is intended to comply with the requirements of Legislative Rule 64CSR3, and other state and federal regulations.

TIERS REPORTING SYSTEM

This water system has elected to use the *Tiered Incident / Event Reporting System (TIERS)* for communicating with the public, agencies, the media, and other entities in the event of a spill or other incident that may threaten water quality. TIERS provides a multi-level notification framework, which escalates the communicated threat level commensurate with the drinking water system risks associated with a particular contamination incident or event. TIERS also includes a procedural flow chart illustrating key incident response communication functions and how they interface with overall event response / incident management actions. Finally, TIERS identifies the roles and responsibilities for key people involved in risk response, public notification, news media and other communication.

TIERS provides an easy-to-remember five-tiered **A-B-C-D-E** risk-based incident response communication format, as described below. Table 1 provides also associated risk levels.

A = Announcement. The water system is issuing an announcement to the public and public agencies about an incident or event that may pose a threat to water quality. Additional information will be provided as it becomes available. As always, if water system customers notice anything unusual about their water, they should contact the water system

B = Boil Water Advisory. A boil water advisory has been issued by the water system. Customers may use the water for showering, bathing, and other non-potable uses, but should boil water used for drinking or cooking.

C = Cannot Drink. The water system asks that users not drink or cook with the water at this time. Non-potable uses, such as showering, bathing, cleaning, and outdoor uses are not affected.

D = Do Not Use. An incident or event has occurred affecting nearly all uses of the water. Do not use the water for drinking, cooking, showering, bathing, cleaning, or other tasks where water can come in contact with your skin. Water can be used for flushing commodes and fire protection.

E = Emergency. Water cannot be used for any reason.

Tier	Tier Category	Risk Level	Tier Summary
A	Announcement	Low	The water system is issuing an announcement to the public and public agencies about an incident or event that could pose a threat to public health and safety. Additional information will be provided as it becomes available.
B	Boil Water Advisory	Moderate	Water system users are advised to boil any water to be used for drinking or cooking, due to possible microbial contamination. The system operator will notify users when the boil water advisory is lifted.

C	Cannot Drink	High	System users should not drink or cook with the water until further notice. The water can still be used for showering, bathing, cleaning, and other tasks.
D	Do Not Use	Very High	The water should only be used for flushing commodes and fire protection until further notice. More information on this notice will be provided as soon as it is available.
E	Emergency	Extremely High	The water should not be used for any purpose until further notice. More information on this notice will be provided as soon as it is available.

COMMUNICATION TEAM

The Communication Team for the water system is listed in the table below, along with key roles. In the event of a spill or other incident that may affect water quality, the water system spokesperson will provide initial information, until the team assembles (if necessary) to provide follow-up communication.

Water system communication team members, organizations, and roles.

Team Member Name	Organization	Phone	Email	Role
Brian Holcomb	Clay Roane PSD	██████████	-	Primary Spokesperson
David Grigsby	Clay Roane PSD	██████████	-	Secondary Spokesperson
Crystal Hayes	Clay Roane PSD	304-548-5209	clayroanepsdvw@frontier.com	Member
Robert Burdette	Clay Roane PSD	304-548-5209	-	Member

In the event of a spill, release, or other incident that may threaten water quality, members of the team who are available will coordinate with the management staff of the local water supplier to:

- Collect information needed to investigate, analyze, and characterize the incident/event
- Provide information to the management staff, so they can decide how to respond
- Assist the management staff in handling event response and communication duties
- Coordinate fully and seamlessly with the management staff to ensure response effectiveness

COMMUNICATION TEAM DUTIES

The communication team will be responsible for working cooperatively with the management staff and state and local emergency response agencies to notify local health agencies and the public of the initial spill or contamination event. The team will also provide updated information related to any contamination or impairment of the source water supply or the system's drinking water supply.

According to Legislative Rule 64CSR3, the initial notification to the public will occur no later than thirty minutes after the public water system becomes aware that the spill, release or potential contamination of the public water system poses a potential threat to public health and safety.

As part of the group implementing the Source Water Protection Plan, team members are expected to be familiar with the plan, including incident/event response and communication tasks. Specifically, team members should:

- Be knowledgeable on elements of the Source Water Protection Plan and Communication Plan
- Attend team meetings to ensure up-to-date knowledge of the system and its functions

- Participate in periodic exercises that “game out” incident response and communication tasks
- Help to educate local officials, the media, and others on source water protection
- Cooperate with water supplier efforts to coordinate incident response communication
- Be prepared to respond to requests for field investigations of reported incidents
- Not speak on behalf of the water supplier unless designated as the system’s spokesperson

The primary spokesperson will be responsible for speaking on behalf of the water system to local agencies, the public, and the news media. The spokesperson should work with the management staff and the team to ensure that all communication is clear, accurate, timely, and consistent. The spokesperson may authorize and/or direct others to issue news releases or other information that has been approved by the system’s management staff. The spokesperson is expected to be on call immediately when an incident or event which may threaten water quality occurs. The spokesperson will perform the following tasks in the event of a spill, release, or other event that threatens water quality:

- Announce which risk level (A, B, C, D, or E) will apply to the public notifications that are issued (see example press releases)
- Issue news releases, updates, and other information regarding the incident/event
- Use the news media, email, social media, and other appropriate information venues
- Ensure that news releases are sent to local health agencies and the public
- Respond to questions from the news media and others regarding the incident/event
- Appear at news conferences and interviews to explain incident response, etc.

INCIDENT / EVENT COMMUNICATION PROCEDURE

The flow chart in this section illustrates how the water system will respond when it receives a report that a spill, release, or other contamination event may have occurred. Key elements of the flow chart are described below.

Communication with agencies, the public, and the media during threat incidents

Upon initial notification of the incident/event, system managers and staff will collect information and verify the need for further investigation. Only properly trained personnel will perform onsite investigations if permitted by emergency responders. If further investigation is warranted, and the initial facts support it, the water system spokesperson will issue a public communication statement consistent with the threat level. In addition, water system personnel and partners will be dispatched to conduct reconnaissance, a threat assessment, and a threat characterization, if present. This work may include:

- Verification of the incident/event type (spill, release, etc.)
- Location of incident/event
- Type of material(s) involved in spill, release, etc.
- Quantity of material involved
- Potential of the material to move, migrate, or be transported
- Relevant time factor(s) in the risk assessment (e.g., downstream movement rate)
- Overall level of risk to water system, whether low, moderate, high, or very high
- Development of the initial risk characterization

As the flow chart indicates, several iterative cycles will occur after the initial threat assessment, including communication with local agencies and the public, further investigation of the incident, possible implementation of the water system’s contingency plan, and eventual elimination of the threat and a return to normal operations. Communication activities during this period will include:

- The initial release (i.e., **Announcement**, **Boil Water Advisory**, **Cannot Drink**, **Do Not Use**, or **Emergency**, see attached example press releases)
 - Sent to local health agencies, the public, and the news media within 30 minutes
- Notification of the local water system’s source water protection and communication teams
 - If warranted by initial findings regarding the spill, release, or incident
- Notification of the WV Bureau of Public Health

- As required
 - Periodic information updates, as incident response information is received
 - Updates to the applicable A-B-C-D-E advisory tier, as necessary

If time permits and the need arises, after the threat level is reduced, and operations return to normal, the water system staff, the communication and source water protection teams, and their partners may conduct a post-event review and assessment. The purpose of the review is to examine the response to the incident, relevant communication activities, and overall outcomes. Plans and procedures may be updated, altered, or adapted based on lessons learned through this process.

TIERS FLOW CHART

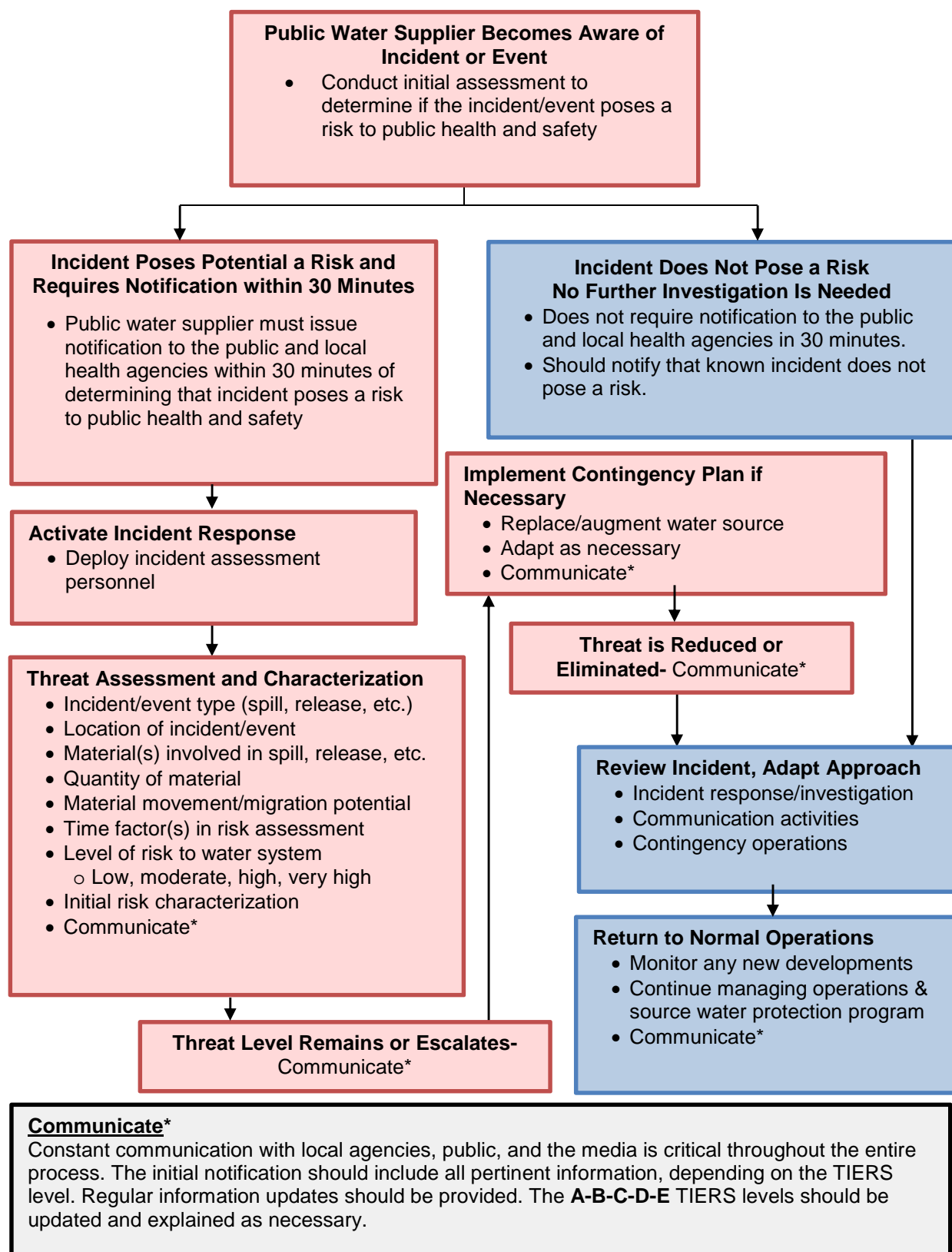

EMERGENCY SHORT FORMS

Emergency Communication Information

	Name	Phone Number	Email	
Designated spokesperson:	Brian Holcomb	██████████	-	
Alternate spokesperson:	David Grigsby	██████████	-	
Designated location to disseminate information to media:	Radio WCWV 92.9 FM C-93 Summersville. Clay Roane PSD has Facebook page. Clayberry.org is a community website.			
Methods of contacting affected residents:	Word of mouth	x	Posted notices	x
	Door-to-door canvassing	x	Radio	x
	Newspaper		Social Media	x
Media contacts:	Name	Title	Phone Number	Email
	WSAZ TV 3	-	304-523-5333	
	WVOK 13	-	304-525-1313	
	WCBS 8 / WVAH 11	-	304-345-4115	

Emergency Services Contacts

	Name	Emergency Phone	Alternate Phone	Email
Local Police	Clay County Sheriff	911	304-587-4260	-
Local Fire Department	Clay Volunteer Fire Department	911	304-550-0956	-

Local Ambulance Service	Clay Ambulance Authority	911	304-587-2554	-
Hazardous Material Response Service	Mutual aid agreement with Kanawha County	911	-	-

Key Personnel

	Name	Title	Phone	Email
Key staff responsible for coordinating emergency response procedures?	Crystal Hayes	General Manager	304-548-5209	clayroanepsdvw@frontier.com
	Robert Burdette	Chief Operator	304-548-5209	-
Staff responsible for keeping confidential PSSC information and releasing to emergency responders:	Crystal Hayes	General Manager	304-548-5209	clayroanepsdvw@frontier.com
	Robert Burdette	Chief Operator	304-548-5209	-

Sensitive Populations

Other communities that are served by the utility:	Wallback, Amma, and Left Hand		
Major user/sensitive population notification:	Name	Emergency Phone	Alternate Phone
	Geary Middle School	304-565-3721	-
EED District Office Contact:	Name	Phone	Email
	J.D. Douglas	(304) 722-0615	-

OEHS Readiness Coordinator		Warren Von Dollen	304-356-4290 (main) 304-550-5607 (cell)	warren.r.vondollen@wv.gov
Downstream Water Contacts:	Water System Name	Contact Name	Emergency Phone	Alternate Phone
	WVAW Elk River Plant	Jeffrey McIntyre	304-353-6300	-
Are you planning on implementing the TIER system?		Yes		

Emergency Response Information

List laboratories available to perform sample analysis in case of emergency:	Name	Phone
	REI Consultants	304-255-2500
	WV Office of Lab Services	304-558-3530
Has the utility developed a detailed Emergency Response Plan in accordance with the Public Health Security Bioterrorism Preparedness and Response Pan Act of 2002?	Yes	
When was the Emergency Response Plan developed or last updated?	mid 2000s	

EMERGENCY CONTACT INFORMATION

State Emergency Spill Notification

1-800-642-3074

Office of Emergency Services

<http://www.wvdhsem.gov/>
Charleston, WV- (304) 558-5380

WV Bureau for Public Health Office of Environmental Health Services (OEHS)www.wvdhhr.org/oehs*Readiness Coordinator- Warren Von Dollen*

Phone; 304-356-4290

Cell; 304-550-5607

E-mail; warren.r.vondollen@wv.gov

Environmental Engineering Division Staff
Charleston, Central Office (304) 558-2981
Beckley, District 1 (304) 256-6666
St. Albans, District 2 (304) 722-0611
Kearneysville, District 4 (304) 725-9453
Wheeling, District 5 (304) 238-1145
Fairmont, District 6 (304) 368-2530

National Response Center - Chemical, Oil, & Chemical/Biological Terrorism

1-800-424-8802

WV State Fire Marshal's Office

1-800-233-3473

West Virginia State Police

1-304-746-2100

WV Watch – Report Suspicious Activity

1-866-989-2824

DEP Distance Calculator<http://tagis.dep.wv.gov/pswcheck/>

PRESS RELEASE ATTACHMENTS

TIERS Levels A, B, C, D, and E

**UTILITY ISSUED NOTICE – LEVEL A
PUBLIC WATER SYSTEM ANNOUNCEMENT
A WATER SYSTEM INVESTIGATION IS UNDERWAY**

On _____ at ____:____ AM/PM, the _____ Water System began investigating an incident that may affect local water quality.

The incident involves the following situation at this location:

There are no restrictions on water use at this time. As always, if water system customers notice anything unusual about their water – such as abnormal odors, colors, sheen, etc. – they should contact the water system at _____.

At this time there is no need for concern if you have consumed or used the water.

Regular updates will be provided about this Announcement as water system staff continue their investigation. Again, there are no restrictions on water use at this time.

State Water System ID# _____ Date Distributed: _____

UTILITY ISSUED NOTICE – LEVEL B
BOIL WATER ADVISORY
A BOIL WATER ADVISORY IS IN EFFECT

On _____ at ____:____ am/pm, a water problem occurred causing contamination of your water. The areas that are affected are as follows:

Entire Water System or Other: _____

CONDITIONS INDICATE THERE IS A HIGH PROBABILITY THAT YOUR WATER IS CONTAMINATED. TESTING HAS NOT OCCURRED TO CONFIRM OR DENY THE PRESENCE OF CONTAMINATION IN YOUR WATER.

What should I do?

- **DO NOT DRINK THE WATER WITHOUT BOILING IT FIRST.** Bring all water to a boil, let it boil for one minute, and let it cool before using, or use bottled water. Boiled or bottled water should be used for drinking, making ice, brushing teeth, washing dishes, bathing, and food preparation **until further notice**. Boiling kills bacteria and other organisms in the water.

What happened?

- **The problem is related to** _____

What is being done?

- **The water system is taking the following action:** _____

What should a customer do if they have consumed or used the water?

- _____

We will inform you when you no longer need to boil your water. We anticipate resolving the problem within _____ hours/days. For more information, please contact _____ at _____ or _____ at _____.

General guidelines on ways to lessen the health risk are available from the EPA Safe Drinking Water Hotline at 1 (800) 426-4791.

Please share this information others who use this water, especially those who may not have received this notice directly (for example, people in apartments, nursing homes, schools, and businesses). You can do this by posting this notice in a public place or distributing copies by hand or mail.

This notice was distributed by _____

State Water System ID# _____ Date Distributed: _____

UTILITY ISSUED NOTICE – LEVEL C
“CANNOT DRINK” WATER NOTIFICATION
A LEVEL C WATER ADVISORY IS IN EFFECT

On _____ at ____:____ am/pm, a water problem occurred causing contamination of your water. The areas that are affected are as follows:

Entire Water System or Other: _____

CONDITIONS INDICATE THERE IS A HIGH PROBABILITY THAT YOUR WATER IS CONTAMINATED. TESTING HAS NOT OCCURRED TO CONFIRM OR DENY THE PRESENCE OF CONTAMINATION IN YOUR WATER.

What should I do?

- **DO NOT DRINK THE WATER.** You can't drink the water, but you can use it for showering, bathing, toilet-flushing, and other non-potable purposes.
- **BOILING WILL NOT PURIFY THE WATER.** Do not drink the water, even if it is boiled. The type of contamination suspected is not removed by boiling.

What happened?

- The problem is related to _____

What is being done?

- The water system is taking the following action: _____

What should a customer do if they have consumed or used the water?

- _____

We will inform you when the water is safe to drink. We anticipate resolving the problem within _____ hours/days. For more information – or to report unusual water conditions such as abnormal odors, colors, sheen, etc. – please contact _____ at _____ or _____ at _____.

Please share this information others who use this water, especially those who may not have received this notice directly (for example, people in apartments, nursing homes, schools, and businesses). You can do this by posting this notice in a public place or distributing copies by hand or mail.

This notice was distributed by _____

State Water System ID# _____ Date Distributed: _____

UTILITY ISSUED NOTICE – LEVEL D
“DO NOT USE” WATER NOTIFICATION
A LEVEL D WATER ADVISORY IS IN EFFECT

On _____ at ____:____ am/pm, a water problem occurred causing contamination of your water. The areas that are affected are as follows:

Entire Water System or Other: _____

CONDITIONS INDICATE THERE IS A HIGH PROBABILITY THAT YOUR WATER IS CONTAMINATED. TESTING HAS NOT OCCURRED TO CONFIRM OR DENY THE PRESENCE OF CONTAMINATION IN YOUR WATER.

What should I do?

- **DO NOT DRINK THE WATER.** The water is contaminated.
- **DO NOT SHOWER OR BATHE IN THE WATER.** You can’t use the water for drinking, showering, or bathing. It can be used for toilet flushing and firefighting.
- **BOILING WILL NOT PURIFY THE WATER.** Do not use the water, even if it is boiled. The type of contamination suspected is not removed by boiling.

What happened?

- **The problem is related to** _____

What is being done?

- **The water system is taking the following action:** _____

What should a customer do if they have consumed or used the water?

- _____

We will inform you when the water is safe to drink. We anticipate resolving the problem within _____ hours/days. For more information – or to report unusual water conditions such as abnormal odors, colors, sheen, etc. – please contact _____ at _____ or _____ at _____.

Please share this information others who use this water, especially those who may not have received this notice directly (for example, people in apartments, nursing homes, schools, and businesses). You can do this by posting this notice in a public place or distributing copies by hand or mail.

This notice was distributed by _____

State Water System ID# _____ Date Distributed: _____

**UTILITY ISSUED NOTICE – LEVEL E
EMERGENCY WATER NOTIFICATION
A LEVEL E WATER ADVISORY IS IN EFFECT**

On _____ at ____:____am/pm, a water problem occurred causing contamination of your water. The areas that are affected are as follows:

Entire Water System or Other: _____

CONDITIONS INDICATE THERE IS A HIGH PROBABILITY THAT YOUR WATER IS CONTAMINATED. TESTING HAS NOT OCCURRED TO CONFIRM OR DENY THE PRESENCE OF CONTAMINATION IN YOUR WATER.

What should I do?

- **DO NOT DRINK THE WATER.** The water is contaminated.
- **DO NOT USE THE WATER FOR ANY PURPOSE!** You can't use the water for drinking, showering, or bathing, or any other use – not even for toilet flushing.
- **BOILING WILL NOT PURIFY THE WATER.** Do not use the water, even if it is boiled. The type of contamination suspected is not removed by boiling.

What happened?

- The problem is related to _____

What is being done?

- The water system is taking the following action: _____

What should a customer do if they have consumed or used the water?

- _____

We will inform you when the water is safe to drink. We anticipate resolving the problem within _____ hours/days. For more information – or to report unusual water conditions such as abnormal odors, colors, sheen, etc. – please contact _____ at _____ or _____ at _____.

Please share this information others who use this water, especially those who may not have received this notice directly (for example, people in apartments, nursing homes, schools, and businesses). You can do this by posting this notice in a public place or distributing copies by hand or mail.

This notice was distributed by _____

State Water System ID# _____ Date Distributed: _____

APPENDIX D. SINGLE SOURCE FEASIBILITY STUDY

ENGINEERING STUDY FOR CONTINGENCY PLANNING

Clay Roane Public Service District
PWSID No. WV3300806

Prepared for:

Clay Roane Public Service District
PO Box 8
Procious, West Virginia 25164

Prepared by:

Potesta & Associates, Inc.
7012 MacCorkle Avenue, SE
Charleston, West Virginia 25304
Phone: (304) 342-1400 Fax: (304) 343-9031
Email: potesta@potesta.com

Project No. 0101-15-0023-030

August 26, 2015



(This document contains 22 pages, plus appendices.)

POTESTA

TABLE OF CONTENTS

1.0	INTRODUCTION	1
2.0	GENERAL METHODOLOGY	2
3.0	CLAY ROANE PSD SUMMARY.....	4
4.0	SINGLE SOURCE ANALYSIS.....	4
4.1	Descriptions of Alternative Source Water Options	5
4.1.1	Backup Intake and Reservoir (Option A1)	5
4.1.2	Wells (Option A2).....	6
4.1.3	Raw Water Storage (Option B1).....	8
4.1.4	Treated Water Storage (Option B2)	8
4.1.5	Interconnections with Another SWP (Options C1 and C2).....	9
4.1.5.1	West Virginia American Water via Queen Shoals PSD (Option C1).....	9
4.1.5.2	Town of Clay Water Department (Option C2)	10
4.1.6	Other Alternative Source Water Option: Abandoned Mine Pool Withdrawal (Option D).....	12
4.2	Feasibility Matrix Result Summary	12
4.3	Detailed Study Analysis.....	14
5.0	OTHER WATER SYSTEM INFORMATION REQUIRED FOR UPDATED SOURCE WATER ASSESSMENT PROTECTION PLAN REPORT	14
5.1	Ability to Isolate or Divert Contaminated Waters	14
5.2	Ability to Switch to Alternative Water Source or Surface Water Intake.....	15
5.3	Ability to Close Water Supply, Duration of Closure, and Examination of Existing Storage Capacity	15
5.4	Early Warning Monitoring System Implementation.....	15
5.5	Ability to Operate During a Power Outage.....	17
5.6	Unaccounted for Water	18
5.7	Ability to Meet Future Water Supply	18
6.0	CONCLUSIONS AND RECOMMENDATIONS	18
7.0	CLOSING	19

APPENDICES

Feasibility Matrix.....	APPENDIX A
Preliminary Opinion of Total Estimated Capital Cost for Options A1, B1, and C2.....	APPENDIX B
Schematic of Existing Systems in the Vicinity of Clay Roane PSD/Town of Clay Water Department Interconnection Location and Proposed Interconnection Upgrades.....	APPENDIX C
Quotation for Early Warning Monitoring System.....	APPENDIX D

LIST OF ACRONYMS

4-methylcyclohexanemethanol	MCHM
Bureau for Public Health	BPH
Code of State Rule	CSR
Federal Emergency Management Agency	FEMA
Hydraulic Grade Line	HGL
Monthly Operational Reports.....	MOR
Oxidation Reduction Potential.....	ORP
Potesta & Associates, Inc.....	POTESTA
Pressure Reducing Valve	PRV
Public Service District	PSD
Regional Intergovernmental Council.....	RIC
Safe Drinking Water Act	SDWA
Source Water Assessment and Protection.....	SWAP
Source Water Protection Plan.....	SWPP
Source Water Provider.....	SWP
State Historic Preservation Office	SHPO
Ultraviolet Absorbance Sensor	UVAS
United States Army Corp of Engineers	USACE
United States Fish and Wildlife Service	USFWS
United States Geologic Survey	USGS
Water Treatment Plant	WTP
West Virginia American Water	WVAW
West Virginia Department of Environmental Protection.....	WVDEP
West Virginia Department of Health and Human Resources	WVDHHR
West Virginia Division of Highways.....	WVDOH
West Virginia Geologic and Economic Survey	WVGES
West Virginia Infrastructure & Jobs Development Council.....	IJDC
West Virginia Public Lands Corporation.....	PLC
West Virginia Public Service Commission.....	PSC

ENGINEERING STUDY FOR CONTINGENCY PLANNING

Clay Roane Public Service District *PWSID No. WV3300806*

1.0 INTRODUCTION

Since 1974, the federal Safe Drinking Water Act (SDWA) has set minimum standards on the construction, operation, and quality of water provided by public water systems. The Safe Drinking Water Act Amendments of 1996 expanded the concept of wellhead protection to include surface water sources under the umbrella term of Source Water Protection. The SDWA required states to develop and implement a Source Water Assessment and Protection (SWAP) program designed to evaluate the vulnerability of public drinking water systems to possible sources of contamination, and encourages states to work with these systems in developing protection and management plans. In 1999, the West Virginia Department of Health and Human Resources (WVDHHR) published the West Virginia Source Water Assessment and Protection Program, which was endorsed by the United States Environmental Protection Agency. Although Clay Roane Public Service District (PSD) treats its water to meet federal and state drinking water standards, conventional treatment does not fully eradicate all potential contaminants, and treatment that goes beyond conventional methods is often very expensive. The purpose of a Source Water Protection Plan (SWPP) is to describe what the source water provider (SWP) has done, is currently doing, and plans to do to protect its source of drinking water. Clay Roane PSD completed an SWPP on May 14, 2010.

On January 9, 2014, approximately 7,500 gallons of 4-methylcyclohexanemethanol (MCHM) leaked out of an aboveground storage tank, owned by Freedom Industries, Inc., which was situated on the east bank of the Elk River. The liquid MCHM entered the Elk River approximately 1.5 miles upstream of West Virginia American Water's (WVAW) source water intake for over 300,000 people in the Charleston, West Virginia area. The potable water supply was adversely impacted. In response to the Freedom Industries, Inc. leak, Senate Bill 373 (containing the Public Water Supply Protection Act §22-31) was approved by the 2014 Legislature and signed into law by Governor Earl Ray Tomblin on April 1, 2014. The law officially took effect on June 6, 2014. The Bureau for Public Health (BPH) submitted rule revisions for Legislative Rule 64 Code of State Rule (CSR) 3 Public Water Systems to the Secretary of State's office with respect to source water protection planning enacted in Senate Bill 373. The Public Water Supply Protection Act and Legislative Rule 64CSR3 requires SWPs, such as the Clay Roane PSD, to update their SWPP. This update requires an engineering study which details a technical and economic examination of alternative source water options in the event the provider's source water is contaminated (i.e., single source analysis) in addition to other water system information.

The West Virginia Legislature appointed monies to the BPH, a division of WVDHHR, to financially assist SWPs with updates required in Senate Bill 373. The BPH in turn transferred a portion of the monies to the various regional planning and development councils, including the Regional Intergovernmental Council (RIC) in South Charleston, West Virginia, to procure and manage engineering firms providing engineering services associated with updating SWPPs. Potesta & Associates, Inc. (POTESTA) was selected by RIC to prepare this Engineering Study for Contingency Planning for the Updated Source Water Assessment and Protection Plan Report. This will assist Clay Roane PSD with the required engineering portions of the SWPP update. The SWPP update is due to the Commissioner of the BPH on or before July 1, 2016 as stated in §64-3 (14.3, 14.6.b-g).

2.0 GENERAL METHODOLOGY

The object of the report was to evaluate and determine alternative source water options to supply the Clay Roane PSD in the event of spill or contamination of the primary source water supply. Additionally, the report examines other water system information required by the updated SWPP report due to the Commissioner of the BPH by July 1, 2016. Included in the effort was:

1. Met with Clay Roane staff in order to garner knowledge of the Clay Roane PSD's water supply system.
2. Reviewed water utility annual reports; BPH sanitary surveys; monthly operational reports (MORs); West Virginia Geologic & Economic Survey (WVGES) website online coal mapping tool; and "Aquifer-Characteristics Data for West Virginia," U.S. Geologic Survey (USGS) Water-Resources Report 01-4036, 2001.
3. Reviewed Appendix E-Feasibility Study Guidance Document and the associated Feasibility Matrix provided by WVDHHR.
4. Completed identification and feasibility matrix evaluation of alternative source water options.
5. Performed a more detailed study of highest scoring alternative source water option(s) identified by the feasibility matrix, including preparing more detailed rationalization of certain alternative source water options and their estimates of cost.
6. Compiled and/or summarized other Clay Roane PSD water system information:
 - a. SWP's ability to isolate or divert contaminated waters from its water supply, and identification of the amount of raw water storage capacity.
 - b. SWP's ability to switch to an alternative water source or surface water intake in the event of contamination.

- c. SWP's capability to close its water supply in the event the primary water source is contaminated and identification of the duration of time it can keep the water supply closed without creating a public health emergency.
 - d. SWP's examination of existing available storage capacity and how its existing available storage capacity compares to Clay Roane PSD's normal daily usage including total treated water storage, raw water storage and the number of hours of supply capacity.
 - e. An examination of technical and economic feasibility of implementing an early warning monitoring system.
 - f. An analysis of the Clay Roane PSD's ability to operate effectively during power outages including means to supply water through treatment, storage and distribution without creating a public emergency. This step included reviewing the BPH's Emergency Generator Data table that was provided to POTESA.
 - g. An estimation of the calculated level of unaccounted for water, and if the calculated water is greater than 15 percent, identification of measures the SWP is actively taking to reduce the level of water loss.
 - h. Clay Roane PSD's ability to meet future water supply needs by expanding a current source or developing a new one, including a description of current plan and pumping capacity and projections for growth over the next five years that would exceed the current system capacity.
7. Prepared this report in draft format and forwarded it to Clay Roane PSD for review and comment.
 8. Met with Clay Roane PSD as a follow-up to the draft submittal of the report to receive comments on the draft report.
 9. Revised and finalized this report after receiving comments from Clay Roane PSD.
 10. Presented this report at a September 2015 board meeting.

3.0 CLAY ROANE PSD SYSTEM SUMMARY

Clay Roane PSD operates a community public water system which can be summarized as follows:

Clay Roane PSD System Characteristics	Values
Raw Water Intake on the Elk River Adjacent to the WTP	N/A
Population Served	Approximately 2,020
Treatment Capacity	129,600 GPD (90 GPM)
Average Daily Production (MOR 2014)	79,837 GPD (55 GPM)
Maximum Daily Production (MOR 2014)	137,700 GPD (95 GPM)
Raw Water Storage Capacity	0 Gallons*
Treated Water Storage Capacity	480,100 Gallons

* Ignoring small storage available in raw water pump station(s) or presedimentation tank(s).

4.0 SINGLE SOURCE ANALYSIS

Clay Roane PSD is supplied by a single source. Therefore, POTE STA performed an evaluation to determine technically and economically feasible option(s) for Clay Roane PSD. The evaluation process included using the feasibility matrix provided by the WVDHHR. The feasibility matrix allowed POTE STA to evaluate several options at a “high level” using multiple criteria identified by WVDHHR. The options included:

1. Construct or establish a secondary or backup surface water intake (herein called Option A1) or wells (Option A2) which would draw water from a substantially different location or water source.
2. Construct additional raw water storage capacity (Option B1) or treated water storage capacity (Option B2) to provide at least two days of additional system storage based on the plant’s maximum level of production experienced within the last year and following Public Water Systems Design Standards §64-77-9.1.a, §64-77-9.4.
3. Create or construct operational interconnection(s) with another SWP to allow the SWP to receive its water from a different source of supply or supply (herein called Options C1 and C2).
4. Create or construct other alternative(s) available to the SWP to secure safe and reliable alternative supplies during a period its primary source of supply is unavailable or negatively impacted for an extended period.

If Clay Roane PSD already had multiple sources, then they were also required to evaluate their ability to meet the utility's demands independently for 30, 60, 90 or more days. However, Clay Roane PSD obtains its water from a single source and, therefore, POTESTA did not complete this evaluation.

If one or more of the options were determined to be technologically or economically feasible, POTESTA then performed a detailed study analysis on the comparative costs, risks and benefits of implementing alternative source water options as described in Section 4.3.

4.1 Descriptions of Alternative Source Water Options

The following summarizes the evaluated alternative source water options in more detail:

4.1.1 Backup Intake and Reservoir (Option A1)

POTESTA reviewed the 7Q10 (lowest average discharge over a period of one week with a recurrence interval of 10 years) for three streams (tributaries of the Elk River) within close proximity to the WTP: Dulls Creek, Twistabout Creek, and an Unnamed Tributary (across the street from the WTP). The 7Q10 flow rate for these streams was inadequate to supply Clay Roane PSD with 137,700 gallons per day (95 GPM), the maximum plant flow rate in 2014. However, the nature of some of the nearby tributaries and the relatively small Clay Roane PSD demand could lend themselves to construction of a reservoir that would store enough water to serve as a backup intake. POTESTA moved forward with evaluating this option.

A siting study would be required to identify a recommended tributary. Such an effort is beyond the scope of this study. However, POTESTA identified a tributary near the WTP that we believed typical of a tributary that could host a reservoir near the WTP. POTESTA then conceptualized the design of a reservoir that could contain over 300,000 gallons of water, and an interconnecting 8-inch pipeline to the WTP. This reservoir has the following characteristics:

Pond Volume	=	1.02 acre-feet
Depth of Pond, Ignoring Freeboard	=	10 feet
Sideslopes within Pond	=	3 feet high; 1 foot vertical
Freeboard Height	=	5 feet
Top Width of Water Surface Elevation	=	75 feet
Top Length of Water Surface Elevation	=	135 feet
Bottom Width	=	10 feet
Bottom Length	=	75 feet

It should be noted that these dimensions are simplified to provide a basic estimate. It was assumed that the reservoir would be constructed utilizing an embankment fill, and that an emergency spillway would be provided. Over 8,300 feet of pipe would be required to extend a gravity pipeline to the WTP. If a tributary closer to the WTP could be utilized, the reduction in linear feet of 8-inch HDPE water line could yield significant savings.

POTESTA's preliminary opinion of total estimated project (i.e., capital) cost for a backup intake and reservoir is presented in **Appendix B**.

4.1.2 Wells (Option A2)

In order to evaluate the technical and economic feasibility of a ground water well field as an alternative source water option for Clay Roane PSD, POTESTA referred to "*The Aquifer-Characteristics Data for West Virginia, Water-Resources Investigations Report 01-4036*", which was prepared to assist BPH delineate well-head (source water) protection areas for public-supply wells and well fields in West Virginia in 2001. Report 01-4036's Appendix details specific capacity and transmissivity data segregated by aquifer for selected wells in West Virginia. POTESTA used specific well data from Report 01-4036's Appendix to estimate well yields within close proximity to Clay Roane PSD's WTP (see table below).

Site Identification Number	Longitude	Latitude	County	Hydrogeologic Unit (Aquifer)	Well Depth (ft)	Discharge (gpm)	Draw Down (ft)	Specific Capacity (gpm/ft)	Transmissivity (ft ² /d)
383138081094201	38°31'38"	81°09'42"	Clay	Conemaugh Group	160	8	55	0.15	36
382303081121301	38°23'03"	81°12'13"	Clay	Allegheny Formation	35	16	4	4.00	1,100 (estimated)
383302081160801	38°33'02"	81°16'08"	Roane	Conemaugh Group	57	24	10	2.40	550

There are three wells located approximately 5 miles from Clay Roane's WTP. POTEESTA used the average value to indicate a typical discharge of 16 gallons per minute per well. We have used this value to estimate what a typical well yield would be near the WTP. Clay Roane PSD's maximum production day in 2014 was 95 GPM. This would indicate a need for approximately six wells in order to supply the Clay Roane PSD with 95 GPM. Such a well field would have a high capital cost, would have the potential to locate wells in existing residential areas, and would require ongoing costs to maintain adequate well yields. In addition, the chemistry of ground water commonly varies significantly from nearby surface water possibly resulting in undesirable conditions (taste, color, odor, etc.) unless additional treatment was added. Based on these factors, utilization of wells (i.e., a well field) was deemed not desirable and hence not feasible. Since POTEESTA arrived at this conclusion when evaluating wells for all engineering studies for the RIC SWP's, Option A2 was not entered into the project feasibility matrix for any SWP.

4.1.3 Raw Water Storage (Option B1)

Clay Roane PSD does not currently have any significant raw water storage capacity. Two days supply of water storage estimated from the WTP's maximum level of production in one day (2014) is approximately 275,400 gallons. Clay Roane PSD's current treated water storage capacity is 480,100 gallons (see Section 4.1.4). Therefore, Clay Roane PSD satisfies the requirement set forth in Senate Bill 373 that states the submitted plan shall include an examination and analysis of the technical and economic feasibility of constructing additional raw water storage capacity and/or treated water storage capacity, to provide at least two days of system storage based on the plant's maximum level of production experienced within the past year as an alternative source water option.

Since Clay Roane PSD does not currently have any significant raw water storage capacity, and their treated water storage capacity meets guidelines set forth by Senate Bill 373, POTEESTA added an input for raw water storage to the feasibility matrix to add flexibility to their water system. The "rule of thumb" cost for a 300,000-gallon raw water tank (rounded up from 275,400 gallons) was input into the feasibility matrix and includes costs for the tank and roof (further study might eliminate the need for such a roof), mobilization, foundation, valve vault/piping, and other factors. It is assumed that this storage tank would be located in the field at the front of the WTP.

The preliminary opinion of total estimated project (i.e., capital) cost for this option is presented in **Appendix B**.

4.1.4 Treated Water Storage (Option B2)

Clay Roane PSD Treated Water Storage Tanks	Gallons
Left Hand Tank	190,800
Amma Tank	68,100
Ovapa Tank	104,900
Camp Creek (Queen Shoals) Tank	19,900

Clay Roane PSD Treated Water Storage Tanks	Gallons
Cantrell (Twistabout) Tank	48,200
Hooks Tank	48,200
<i>Total Treated Water Storage:</i>	<i>480,100</i>

Two days supply of water storage estimated from the WTP's maximum level of production in one day (2014) is approximately 275,400 gallons. Clay Roane PSD's current treated water storage capacity is 480,100 gallons. Clay Roane PSD purchased an average of 67,400 gallons per day in 2014 from the Town of Clay Water Department. If Clay Roane PSD added an average two days of purchased water (134,800 gallons) to two days of maximum production level from 2014 (275,400 gallons) set forth by Senate Bill 373, their potential system demand could be 410,121 gallons in a two-day period. Clay Roane PSD's current treated water storage of 480,100 gallons meets this higher benchmark.

POTESTA evaluated additional raw water tankage rather than water tanks storing treated water because adding additional treated water tankage may not allow adequate turnover of the treated water as set forth in §64-77-9.4. A lack of adequate turnover can create water quality issues with treated water in the distribution system. Similarly, Appendix E-Feasibility Study Guidance Documents provided by WVDHHR notes that studies examining the alternative of additional raw and/or treated water must comply with existing design standards regulating treated water storage, including minimum storage capacity and adequate turn-over requirements (§64-77-9.1.a, §64-77-9.4). More importantly, POTESTA believes that relying solely on treated water storage is not prudent as much of the storage may not be available when required. The storage may not be available at certain times of the day due to diurnal demand patterns, and due to the fact that water main failures, leaks, etc. can rapidly deplete water storage volumes.

Based on this design standards constraint, adding treated water tankage was deemed not feasible and, therefore, Option B2 was scored "zero" when entered into the feasibility matrix.

4.1.5 Interconnections with Another SWP (Options C1 and C2)

The Clay Roane PSD system lies near two other source water providers. These include:

- West Virginia American Water via Queen Shoals PSD (Option C1)
- The Town of Clay Water Department (Option C2)

Brief evaluations were completed of both SWPs to assess the feasibility of interconnections with Clay Roane PSD. A summary of the evaluations follows.

4.1.5.1 West Virginia American Water via Queen Shoals PSD (Option C1)

An emergency interconnection to serve Clay Roane PSD from the West Virginia American Water (WVAW) Kanawha Valley system was reviewed as an alternative source water option. WVAW sells water to Queen Shoals PSD, whose system is in close proximity to the southern

end of the Clay Roane PSD system. However, Queen Shoals PSD's system is a small system and has had recent financial difficulties. Upgrades would be necessary to the Queen Shoals PSD and Clay Roane PSD systems. In addition, it would likely be necessary to negotiate with two entities (WVAW and Queen Shoals PSD) rather than one. As a result of this, a preliminary cost estimate of the upgrades necessary between the two utilities was not performed.

Therefore, an Interconnection with WVAW via Queen Shoals PSD was deemed not feasible. Option C1 was not entered into the feasibility matrix.

4.1.5.2 Town of Clay Water Department (Option C2)

The Town of Clay Water Department has a WTP on the Elk River and operates a distribution system that serves customers in the Town of Clay and outlying areas. They sell water to Clay Roane PSD and others. Clay Roane PSD has an agreement with the Town of Clay Water Department that allows Clay Roane PSD to purchase 5,000,000 gallons per month (i.e., approximately 115 GPM). The location of purchase is the Varneytown master meter. Clay Roane PSD has this agreement as the limited capacity of the Clay Roane WTP restricts their ability to supply all their demand. A summary of 2014 water produced by Clay Roane PSD purchases from the Town of Clay Water Department and Clay Roane PSD system demand follows:

Month	Gallons Produced by Clay Roane PSD	Gallons Purchased from Town of Clay Water Department	Clay Roane PSD System Demand (gallons)
January	2,079,600	3,463,000	5,542,600
February	2,313,000	2,624,000	4,937,000
March	2,496,600	1,986,000	4,482,600
April	2,403,500	2,640,000	5,043,500
May	2,519,400	2,051,000	4,570,400
June	2,544,900	1,657,000	4,201,900
July	2,416,650	1,837,000	4,253,650
August	2,336,600	1,718,500	4,055,100
September	2,373,300	1,570,500	3,943,800
October	2,454,600	1,856,500	4,311,100
November	2,570,000	1,264,500	3,834,500
December	2,632,300	1,918,500	4,550,800
Total Gallons:	29,140,450	24,586,500	53,726,950
Average GPD 2014 (rounded):	79,800	67,400	147,200

Currently, Clay Roane PSD and the Town of Clay Water Department systems are configured whereas the Town of Clay Water Department can supply water to customers that generally lie north or east of Clay Roane PSD's pressure reducing valve (PRV) along State Route 4 (i.e., State Route 4 PRV). This includes customers in Varneytown and those served by Clay Roane PSD's

Ovapa, Lefthand, and Amma water storage tanks. This PRV allows water to flow from the Town of Clay Water Department as the hydraulic grade line (HGL) of the Town of Clay Water Department system is lower than the Cantrell tank (which feeds the PRV). Flow preferential, without the PRV, would be from the Cantrell tank. This PRV (and the lower Town of Clay Water Department system HGL) prevents the Town of Clay Water Department from being able to provide water to customers of Clay Roane PSD who lie generally west and south of the PRV, including those customers served by the Hooks tank, Pumpkin Ridge booster station/bladder tank, and the Queen Shoals (i.e., Camp Creek) tank. See Schematic of Existing Systems in the Vicinity of the Clay Roane PSD and the Town of Clay Water Department Interconnection Location and Proposed Interconnection Upgrades presented in **Appendix C**.

To allow for the Town of Clay to serve the entire Clay Roane PSD system demand, POTESTA believes it would be necessary for Clay Roane PSD to:

1. Add an emergency bypass booster station around the State Route 4 PRV.
2. Install an emergency bypass PRV around the Hooks booster station.

As noted above, the average Clay Roane PSD system demand is approximately 147,200 gallons per day, or approximately 102 GPM. The Town of Clay Water Department WTP has a design capacity of 800 GPM. The WTP is reportedly operating an average of 8 hours per day with a current average production in 2014 of 236 GPM. In addition, the Town of Clay Water Department State Route 4 booster station (which would need to “relay” the water to Clay Roane PSD system) is a 250 GPM booster station that only operates an average of 4 hours per day, with peak operation of approximately 12 hours per day (typically when there are line breaks in the Town of Clay Water Department or Clay Roane PSD systems. Given that a 250 GPM booster station can produce 15,000 gallons per hour, or 150,000 in a 10-hour period, 150,000 gallons is more than the entire average Clay Roane PSD demand (147,200 gallons) per the table above. This suggests that the Town of Clay Water Department has the capacity to supply water to Clay Roane PSD in the event of an emergency. This would need to be confirmed via additional effort in the future.

The preliminary opinion of total estimated project (i.e., capital) cost for this option is presented in **Appendix B**.

It should be noted that for Clay Roane PSD to utilize the emergency bypass booster station, Clay Roane PSD may have to “turn off” the Ovapa booster station to avoid pressure fluctuations in the Varneytown area. Also, the proposed emergency bypass booster station would be small in both design flow and horsepower, as there are only a limited number of customers served on the south and west of the State Route 4 PRV, and the HGL differences between the Town of Clay Water Department system and the Cantrell tank are small.

Additional design, including flow testing and/or computer modeling, would be necessary to confirm the design concept described above.

4.1.6 Other Alternative Source Water Option: Abandoned Mine Pool Withdrawal (Option D)

POTESTA used the WVGES's website to identify potential options for accessing abandoned mines for source water. The WVGES online coal mapping tool revealed there are no potential substantial abandoned mine pools within proximity to Clay Roane PSD's WTP. An Abandoned Mine Pool Withdrawal was deemed not feasible and, therefore, Option D was scored "zero" when entered into the feasibility matrix.

4.2 Feasibility Matrix Result Summary

POTESTA used the feasibility matrix to rank alternative source water options that "passed" the first evaluation described in Section 4.1. The feasibility matrix addresses economic, technical and environmental criterion, as noted in the feasibility matrix in **Appendix A**. Table 4.2 presents a summary of the alternative source water options in the feasibility matrix (also included are the options that did not "pass" the initial evaluation). Table 4.2 presents the option ranking per the feasibility matrix score, the preliminary opinion of total estimated project (i.e., capital) cost and advantages and disadvantages. Option C2 – Interconnection with the Town of Clay Water Department ranked the highest.

It should be noted that total budget year cost to operate and maintain Clay Roane PSD is a required data input field in the feasibility matrix. POTESTA used the total operation and maintenance expenses located on Page 603D of Clay Roane's Annual Report for Year Ended 2014 to fill the data field. "Rule of thumb" cost estimates were used to fill additional input fields in the feasibility matrix. In some cases, POTESTA developed estimates of costs for other SWP systems being studied by POTESTA, and interpolated or extrapolated those costs to alternative source water options being studied at the Clay Roane PSD.

Table 4.2: Summary of Alternative Source Water Options, Including Feasibility Matrix Results

Alternative Source Water Option	Option Ranking per Feasibility Matrix Score In Appendix A	Summary of Major Construction*	Preliminary Opinion of Total Estimated Project (i.e., Capital) Cost	Advantages	Disadvantages
Backup Intake and Reservoir (Option A1)	3	<ul style="list-style-type: none"> ◆ Mobilization/Demobilization ◆ Access Road ◆ Pond Construction ◆ Over 8,300 feet, 8-inch Water Line ◆ Valve Vault and Piping ◆ Manholes (17) 	\$1,300,000	<ul style="list-style-type: none"> ◆ Backup source independent from other SWP's constraints. ◆ Separate source than Elk River. ◆ Would not have to renegotiate contract with Town of Clay Water Department. 	<ul style="list-style-type: none"> ◆ High capital cost. ◆ Limited supply of water relative to interconnection with Town of Clay Water Department. ◆ Water line and pond maintenance. ◆ Permitting difficulty.
Well (Option A2)	N/A	N/A	N/A	N/A	N/A
Raw Water Storage (Option B1)	2	<ul style="list-style-type: none"> ◆ 300,00 Gallon Tank ◆ Mobilization ◆ Valving/Piping ◆ Site Work 	\$800,000	<ul style="list-style-type: none"> ◆ Raw water readily available. ◆ Would not have to renegotiate contract with Town of Clay Water Department 	<ul style="list-style-type: none"> ◆ Negative aesthetic impacts. ◆ Potential odor issues. ◆ Limited supply of water relative to interconnection with Town of Clay Water Department.
Treated Water Storage (Option B2)	N/A	N/A	N/A	N/A	N/A
Interconnection with WVAW via Queen Shoals PSD (Option C1)	N/A	N/A	N/A	N/A	N/A
Interconnection with Town of Clay Water Department (Option C2)	1	<ul style="list-style-type: none"> ◆ Connection to Existing Water Line ◆ Emergency Bypass Booster Station ◆ Emergency Bypass PRV 	\$200,000	<ul style="list-style-type: none"> ◆ Low capital costs. ◆ Ease of permitting. ◆ 5,000,000 gallon per month contract in place. 	<ul style="list-style-type: none"> ◆ Same source water (Elk River), unless Town of Clay Water Department obtains an alternative backup source water (e.g., intake on Buffalo Creek). ◆ May have to negotiate increase in 5,000,000 gallons per month contract.
Abandoned Mine Pool Withdrawal (Option D)	N/A	N/A	N/A	N/A	N/A

* Quantities approximate.

4.3 Detailed Study Analysis

Option C2, Interconnection with the Town of Clay Water Department ranked the highest in the feasibility matrix. Option B1, Raw Water Storage was the second ranking option followed by Option A1, Backup Intake on Reservoir.

The Interconnection with the Town of Clay Water Department is the lowest capital cost option. Additionally, Clay Roane PSD has a contract in place for 5,000,000 gallons per month. The table in Section 4.1.5.2 of this report illustrates Clay Roane PSD's system demand for each month in 2014 which only exceeded 5,000,000 gallons during two months in 2014. While this suggests adequate water is likely available from the Town of Clay Water Department, it also suggests that the existing contract may need to be renegotiated to extend the limit above 5,000,000 GPM. The main disadvantage of this option is the Town of Clay Water Department obtains source water from the Elk River which is Clay Roane PSD's source water. The Town of Clay Water Department is evaluating a potential backup intake on Buffalo Creek, as a separate source from the Elk River.

The Raw Water Storage, Option B1, has several disadvantages including high capital cost, potential odor issues, and limited supply of water compared to the interconnection. However, there is space for a large storage tank on Clay Roane PSD's field in front of the WTP and the raw water would be readily available.

The Backup Intake and Reservoir, Option A1, provides a separate source than the Elk River and does not limit Clay Roane PSD to the Town of Clay Water Departments constraints. Conversely, it has the highest capital cost, highest maintenance costs, and it only provides a few days supply of water.

5.0 OTHER WATER SYSTEM INFORMATION REQUIRED FOR UPDATED SOURCE WATER ASSESSMENT PROTECTION PLAN REPORT

5.1 Ability to Isolate or Divert Contaminated Waters

Clay Roane PSD obtains its source water from an intake on the Elk River. The raw water intake is in the middle of the Elk River. There is a lower and upper intake on one structure so Clay Roane PSD has some flexibility to draw water from different water levels. However, the upper intake is not available much of the time due to low flow conditions.

Clay Roane PSD does not employ diversion booms to isolate or divert contaminated waters from its supply. Clay Roane PSD does not have any significant raw water storage capacity (for purposes of this evaluation, POTESTA ignored raw water that may be in the treatment process).

5.2 Ability to Switch to Alternative Water Source or Surface Water Intake

Clay Roane PSD does not have a second water source or second surface water intake available to switch to in the event of contamination of its primary source water.

5.3 Ability to Close Water Supply, Duration of Closure, and Examination of Existing Storage Capacity

Clay Roane PSD has the ability to close its intake when the operators receive notification of contamination on the Elk River. Treated water storage fluctuates over time due to demand, water loss, production, leaks and other factors. To estimate the duration of time Clay Roane PSD can keep its intake closed before the system loses water, POTESTA reviewed two data points for treated water storage: Full capacity and 50 percent capacity. Clay Roane PSD does not have any significant raw water storage capacity; therefore, for this evaluation, we assumed their supply capacity is based on their treated water storage. If system demand was at Clay Roane PSD's average 2014 production rate plus their average 2014 purchased rate and their treated water storage was full, they could keep their intake closed for 78 hours. If their treated water storage was half full (50 percent capacity) and Clay Roane PSD's demand was at their average system demand 2014 rate, portions of their system would start to lose water in approximately 39 hours. A summary of this evaluation is presented in the table below.

Boone Raleigh PSD	Values	Hours of Supply
Treated Water Capacity (full capacity)	480,100 gallons	78
Treated Water Capacity (50% capacity)	240,050 gallons	39
Raw Water Storage Capacity	0 gallons	0
Average Production Rate + Average Purchased Rate = Average System Demand 2014	55 GPM + 47 GPM = 102 GPM	N/A

Hours of supply would reduce substantially if Clay Roane PSD had to close their intake during demand equal to their maximum production day in 2014. It should also be noted that our estimate of hours of supply, as presented above, assumes that Clay Roane PSD can "match" volumes of water in any given tank with their demands. Typically, these are not equal (i.e., tank volumes will deplete at different rates), so it is possible that certain customers could lose water quicker than the hours of supply described above.

5.4 Early Warning Monitoring System Implementation

Early warning monitoring systems are used by SWPs to continuously monitor incoming source water. These systems allow WTP operators to anticipate changes to the treatment process required to react to storms, algal blooms, industrial discharge, chemical spills, reservoir stratification/de-stratification, construction activity, sewage spills and certain other natural or manmade occurrences. Clay Roane PSD does not have an early warning monitoring system. POTESTA obtained a price quote from HACH Company for an early warning monitoring

system with various options. The quote is presented in **Appendix D**. In essence, installation of the early warning system represents a tradeoff between cost and capabilities. The more capabilities (e.g., the number of probes) a system contains, the higher the cost to implement the system. POTESTA reviewed the quote and identified the probe options for the recommended features. These recommended features are presented in the following table.

Line Item (per Quote in Appendix C)	Part Number	Feature Description	Price
1	580800	Back panel/trough/level (required): This item is a secure casing used to house the probes. WTP staff can go to the trough and check on all of the probes.	\$ 4,500
2	LXV400.99.1A082	Module, probe (6 sensor), SC1000	\$ 1,344
4	LXV402.99.00002	Db Module, display w/o GSM, SC1000: These two line items consist of the sc1000 probe module that can accept six sensors, and the universal controller display module. An operator can just plug in the monitor and it is ready to use without special software configuration. These items include alarms and memory backup.	\$ 2,770
3	YAB018	Card, internal sc1000, 4mA inputs: This item includes additional analog communication capabilities for the controller.	\$ 908
5	9020000	ASSY, PROBE, LDO Model 2, HACH: Probe for dissolved oxygen.	\$ 1,804
6	DRD1R5-WDMP	Oxidation Reduction Potential (ORP) Sensor, Ryton, WDMP Mounting: Probe for ORP.	\$ 904
7	DPD1R1-WDMP	pH Sensor, Ryton, WDMP Mounting: Probe for pH.	\$ 840
8	LXV423.99.10000	SOLITAX t-line sc/immersion probe 0.001-4000 NTU; wiper; PVC: Probe for turbidity.	\$ 3,474
9	LXV418.99.50002	Db Ultraviolet Absorbance Sensor (UVAS) sc PROBE, 5 mm; Probe for UVAS.	\$ 17,305
14	WRTUPGSOLITAX	Instrument startup and two onsite calibrations per year.	\$ 941
Total Cost:			\$ 34,790
SAY:			\$ 35,000

Note: Costs presented above include installation by Hach Company. However, they would not include all installation costs, such as extension of conduit from raw water source to the laboratory, and "soft" costs required to specify and bid the equipment.

SWPs may purchase probes in stages as funds become available. The five probes listed in the table above can monitor a broad range of changes in source water. Sudden changes in dissolved oxygen can indicate toxic conditions that effect algal respiration or increased levels of bacteria using up the oxygen. An ORP sensor may indicate sudden changes for oxidative or reducing species introduced into the water. The acid/base relationships within source water can be monitored by a pH sensor. Turbidity is a measure of suspended solids, which may indicate spills of solids, chemical compounds or increased bacterial levels. An UVAS probe is used to watch

for sudden changes in organic load that would require alternative treatment procedures. As Clay Roane PSD increases their early warning monitoring capabilities, an additional probe to monitor oil in water could be purchased through HACH for approximately \$17,500.

5.5 Ability to Operate During a Power Outage

Generators are commonly used by SWPs to provide power in the event of a power outage. POTESTA reviewed the Emergency Generator Data provided by WVDHHR and information provided by Clay Roane PSD staff. POTESTA then prepared the summary table below.

Water System	Power Requirements	Generator
Water Treatment Plant <ul style="list-style-type: none"> ▪ Raw Water Pumps ▪ High Server Pumps 	(2) 5 Hp Flygt (2) 15 Hp Goulds	Caterpillar (mobile) Generator Model D60-4, Volts 208/120, 3 phase, 60 KW Kohler (stationary) Generator Model 100R0101, Volts 120/240, 3 phase, 90 KW (temporarily out of service)
Hooks Booster Station	(2) 15 Hp Berkeleys	Caterpillar Generator Model D60-4 is moved between WTP, Hooks Booster Station and Ovapa Booster Station.
Queen Shoals/Camp Creek Booster Station	(1) 7.5 Hp Grundfos	Generac (mobile) Generator Model GP17500 E, Volts 240/120, 1 phase, 17.5 KW
Pumpkin Ridge Booster Station	(2) 5 Hp Grundfos	Generac Generator Model GP17500 E is moved between Queen Shoals Booster Station and Pumpkin Ridge Booster Station.
Ovapa Booster Station	(2) 15 Hp Grundfos	Caterpillar Generator Model D60-4 is moved between WTP, Hooks Booster Station and Ovapa Booster Station.

Clay Roane PSD service area is served by Appalachian Power, Black Diamond Power Company, and MonPower, a First Energy Company. Clay Roane PSD has three generators (Caterpillar, Kohler, and Generac) to run the water treatment plant and four booster stations listed in the aforementioned table. The Caterpillar generator is used to run the WTP which consists of two raw water pumps and two high service pumps. The stationary Kohler generator is currently out of service until several items can be obtained such as fuel lines, fuel tank, and a power cord. Once these parts are obtained, the Kohler generator will run the WTP during power outages which will make the Caterpillar generator available for use at the Hooks booster station and the Ovapa booster station. The four booster stations are set up to accept the generators as listed in the table above.

The derecho which occurred on June 29, 2012 is a historical reference in which Clay Roane PSD was without power for two and half weeks. During this extended power outage, the Clay Roane PSD staff continued to provide water to their customers. When a power outage occurs, Clay Roane PSD staff use the Caterpillar generator to run the WTP. They alternate the Generac generator between the Queen Shoals/Camp Creek Booster Station and the Pumpkin Ridge Booster Station. Once the Hooks, Queen Shoals, and Cantrell tanks are full, Clay Roane PSD staff takes the Caterpillar generator from the WTP and run the Ovapa Booster Station to fill the rest of the system. During the derecho, Clay Roane staff rented a third generator from Walker Caterpillar so they would not have to move the generator from the WTP. Once the required parts are obtained for the Kohler generator, they will no longer need to rent a generator from Walker Caterpillar.

Clay Roane PSD loses power a couple times per month for up to a day at a time. Therefore, running their system during power outages is a common occurrence.

5.6 Unaccounted for Water

Clay Roane PSD reports unaccounted water loss at 22 percent on their Water Utility Annual Report 2014. The new Amma/Lefthand water distribution system was installed in 2006. Reportedly, there have been 39 leaks associated with this project as some of the water line was bedded directly on rock resulting in pipe damage. These leaks contribute to Clay Roane PSD's water losses. Clay Roane PSD staff fixes leaks as they identify them and replace meters to reduce water loss. There is no active leak detection program.

5.7 Ability to Meet Future Water Supply

Clay and Roane counties have experienced flat to a slight decline in population growth over the past decade. If demand increases, Clay Roane, PSD should be able to meet the demand using their current mode of operation (i.e., producing water, and purchasing water).

6.0 CONCLUSIONS AND RECOMMENDATIONS

POTESTA offers the following conclusions and recommendations:

1. The Interconnection with the Town of Clay Water Department ranked the highest in the feasibility matrix. Clay Roane PSD should pursue this option. It may be necessary to renegotiate the contract with the Town of Clay Water Department to pursue this option. The Town of Clay Water Department, as a part of their own source water efforts, may contemplate a backup intake on Buffalo Creek which would provide alternative source water than the Elk River in the event the Elk River is contaminated. Clay Roane PSD should track the Town of Clay Water Department's efforts on this.

2. If Clay Roane PSD elects to pursue an option, a more detailed study should be completed to estimate costs and rate impacts to customers.
3. Clay Roane PSD should obtain the required parts for the Kohler generator and rehabilitate the generator to free up the mobile Caterpillar generator to be used at the Hooks and Ovapa booster stations in the event of an emergency. It is possible this could be accomplished via contingency monies from a currently proposed tank replacement project.
4. Clay Roane PSD should develop and implement an active leak detection program to reduce water loss. This would benefit source water protection.
5. Clay Roane PSD should consider purchasing an early warning monitoring system with the five probes outlined in Section 5.4.

7.0 CLOSING

This report has been prepared to aid Clay Roane PSD with engineering portions of the SWPP update due July 1, 2016 as stated in §64-3 (14.3, 14.6.b-g). Its scope is limited to the specific project and location described herein and represents our understanding of factors as presented in this report. If these factors change as additional data concerning this study is obtained, we should be informed so that we may examine the data and, if necessary, modify or revise the conclusions and recommendations presented in this report.

APPENDIX A

Feasibility Matrix

Clay Roane PSD

PWSID: WV3300806

July 30, 2015

Matrix Completed By:

Potesta & Associates, Inc.

Criteria	Question	Backup Intake	Feasibility	Interconnection	Feasibility	Treated Water Storage	Feasibility	Raw Water Storage	Feasibility	Other-Abandoned Mine Pool Withdrawal	Feasibility
Economic Criteria											
	What is the total current budget year cost to operate and maintain the PWSU (current budget year)?	\$486,510		\$486,510		N/A		\$486,510		NA	
Operation and Maintenance (O&M) Costs	Describe the major O&M cost requirements for the alternative	Pond and pipeline maintenance, line flushing, laboratory analysis, 4 hours of operation per week	1	Stand by costs and minimum monthly bill from SWP, additional accounting	2	N/A	0	Miang, (potential) laboratory analysis, tank inspection and cleaning.	2	NA	0
	What is the incremental cost to operate and maintain the alternative?	\$10,000	1	\$1,000	2	N/A	0	\$5,000	2	NA	0
	Cost comparison of the incremental O&M cost to the current budgeted costs (%)	2.06%	1	0.21%	2	N/A	0	1.03%	2	NA	0
O&M-Feasibility Score			1.0		2.0		0.0		2.0		0.0
	Describe the capital improvements required to implement the alternative.	Access road, pond construction, over 8,500 feet 8-inch water line, valve vault and piping,		Connection to existing water line, emergency bypass booster station and pressure reducing valve Annualized capital cost approximated (i.e., rounded value) using assumed 3.0% for 30 years		N/A		Build 500,000 gallon storage tank in front of WTP. Annualized capital cost approximated (i.e., rounded value) using assumed 3.0% for 30 years		NA	
Capital Costs	What is the total capital cost for the alternative?	\$1,300,000	1	\$200,000	2	N/A	0	\$800,000	1	NA	0
	What is the annualized capital cost to implement the alternative, including land and easement costs, convenience tap fees, etc.?	\$66,000	1	\$10,000	2	N/A	0	\$41,000	1	NA	0
	Cost comparison of the alternative's annualized capital cost to the current budgeted costs (%)	13.57%	1	2.06%	2	N/A	0	8.43%	1	NA	0
Capital Cost-Feasibility Score			1.0		2.0		0.0		1.0		0.0
Technical Criteria											
Permitting	Provide a listing of the expected permits required and the permitting agencies involved in their approval:	DHHR, SHPO, USFWS, PSC, UDC, WVDEP, WVDOH, DNR, USACE, PLC	1	DHHR, SHPO, USFWS, PSC, UDC, WVDOH	3	N/A	0	DHHR, SHPO, PLC, UDC, PSC	2	NA	0
	What is the timeframe for permit approval for each permit?	1095 Days Cumulative	2	365 Days Cumulative	3	N/A	0	365 Days Cumulative	2	NA	0
	Describe the major requirements in obtaining the permits (environmental impact studies, public hearings, etc.)	Prepare and submit clearance letters and permit applications, and certificate of convenience. Public hearings possible, depending on PSC and funding source	2	Prepare and submit clearance letters and permit applications, and certificate of convenience. Public hearings possible, depending on PSC and funding source	3	N/A	0	Prepare and submit clearance letters and permit applications, and certificate of convenience. Public hearings possible, depending on PSC and funding source	1	NA	0
	What is the likelihood of successfully obtaining the permits?	Low	1	Good	3	N/A	0	Moderate	2	NA	0
	Does the implementation of the alternative require regulatory exceptions or variances?	None believed	2	No	3	N/A	0	No	2	NA	0
Permitting-Feasibility Score			1.6		3.0		0.0		1.8		0.0
Flexibility	Will the alternative be needed on a regular basis or only used intermittently?	Regular (assumed four hours per week)	2	Intermittently	2	N/A	0	Intermittently	2	NA	0
	How will implementing the alternative affect the PWSU's current method of treating and delivering potable water, including meeting Safe Drinking Water Act regulations? (ex. In the case of storage, will the alternative increase the likelihood of disinfection byproducts?)	Assumed minimal changes in chemicals needed to treat water	2	Believed minimal	3	N/A	0	Unclear, but could have adverse impacts including increasing likelihood of disinfection byproducts. In addition, tankage will take up some of remaining available space at WTP	1	NA	0
Flexibility-Feasibility Score			2.0		2.5		0.0		1.5		0.0

Criteria	Question	Backup Intake	Feasibility	Interconnection	Feasibility	Treated Water Storage	Feasibility	Raw Water Storage	Feasibility	Other-Abandoned Mine Pool Withdrawal	Feasibility
Resilience	Will the alternative provide any advantages or disadvantages to meeting seasonal changes in demand?	None believed	2	No	2	N/A	0	No	2	NA	0
	How resistant will the alternative be to extreme weather conditions such as drought and flooding?	Less resistant in cold weather, as risk of freezing of reservoir increases	2	Resistant	3	N/A	0	Less resistant in cold weather, as risk of freezing in cold weather	2	NA	0
	Will the alternative be expandable to meet the growing needs of the service area?	No	2	Yes	2	N/A	0	No	2	NA	0
Resilience-Feasibility Score			2.0		2.3		0.0		2.0		0.0
Institutional Requirements	Identify any agreements or other legal instruments with governmental entities, private institutions, or other PWSU required to implement the alternative	USACE permitting can take extended time	1	Contract with Town of Clay Water Department could need re-negotiated	2	N/A	0	None	3	NA	0
	Are any development/planning restrictions in place that can act as a barrier to the implementation of the alternative?	None	2	No	3	N/A	0	None	3	NA	0
	Identify potential land acquisitions and easements requirements	Land acquisition for reservoir, easements for water line	1	Land may be required for emergency bypass booster station	2	N/A	0	No, potential site owned by SWP	3	NA	0
Institutional Requirements-Feasibility Score			1.3		2.3		0.0		3.0		0.0
Environmental Criteria											
Environmental Impacts	Identify any environmentally protected areas or habitats that might be impacted by the alternative	Impounding streams can impact fish and wildlife	1	None identified	3	N/A	0	None identified	2	NA	0
Environmental Impacts-Feasibility Score			1.0		3.0		0.0		2.0		0.0
Aesthetic Impacts	Identify any visual or noise issues caused by the alternative that may affect local land uses	Constructing a reservoir in a hollow has risk of being contentious	1	None	2	N/A	0	Negative Aesthetic of 300,000 gallon tank	1	NA	0
	Identify any mitigation measures that will be required to address aesthetic impacts	Achieve local "buy in" to project	1	None	2	N/A	0	None	2	NA	0
Aesthetic Impacts-Feasibility Score			1.0		2.0		0.0		1.5		0.0
Stakeholder Issues	Identify the potential stakeholders affected by the alternative	Customer	1	Customers, SWP, Town of Clay Water Department	2	N/A	0	Customers	2	NA	0
	Identify the potential issues with stakeholders for and against the alternative	Potential impact	1	Potential rate impact	2	N/A	0	Potential rate impact	1	NA	0
	Will stakeholder concerns represent a significant barrier to implementation (or assistance) of the alternative?	Possibly	2	Potentially	2	N/A	0	Yes	2	NA	0
Stakeholder Issues-Feasibility Score			1.3		2.0		0.0		1.7		0.0
Comments		N/A		N/A		N/A		NA		NA	

Instructions: Using the expanded instructions in the "FEASIBILITY STUDY GUIDANCE DOCUMENT", complete the white and gray input cells. Rank each criteria based on the evidence provided and best professional judgement. Rank the criteria 0-3, assuming 0=not feasible and 3=most feasible. The password to edit fillable cells is "swap".

Scoring:

0 – Not feasible. Criterion cannot be met by this alternative and removes the alternative from further consideration.

1 – Feasible but difficult. Criterion represents a significant barrier to successful implementation but does not eliminate it from consideration.

2 – Feasible. Criterion can be met by the alternative.

3 – Very Feasible. Criterion can be easily met by the alternative

Feasibility Matrix

Clay Roane PSD

PWSID: WV3300806

Date: July 30, 2015

Completed By: Potesta & Associates, Inc.

Alternative Strategy Description	Economic Criteria					Technical Criteria							Environmental Criteria					Final Score	Total Capital Cost	Comments	
	Operation and Maintenance Costs	Capital Costs	Total	Total %	Weighted Total	Permitting	Flexibility	Resilience	Institutional Requirements	Total	Total %	Weighted Total	Environmental Impacts	Aesthetic Impacts	Stakeholder Issues	Total	Total %				Weighted Total
Backup Intake	1.0	1.0	2.0	33.3%	13.3%	1.6	2.0	2.0	1.3	6.9	57.8%	23.1%	1.0	1.0	1.3	3.3	37.0%	7.4%	43.9%	\$1,300,000	N/A
Interconnection	2.0	2.0	4.0	66.7%	26.7%	3.0	2.5	2.3	2.3	10.2	84.7%	33.9%	3.0	2.0	2.0	7.0	77.8%	15.6%	76.1%	\$200,000	N/A
Treated water storage	0.0	0.0	0.0	0.0%	0.0%	0.0	0.0	0.0	0.0	0.0	0.0%	0.0%	0.0	0.0	0.0	0.0	0.0%	0.0%	0.0%	N/A	N/A
Raw Water Storage	2.0	1.0	3.0	50.0%	20.0%	1.8	1.5	2.0	3.0	8.3	69.2%	27.7%	2.0	1.5	1.7	5.2	57.4%	11.5%	59.1%	\$800,000	NA
Other-Abandoned Mine Pool Withdrawal	0.0	0.0	0.0	0.0%	0.0%	0.0	0.0	0.0	0.0	0.0	0.0%	0.0%	0.0	0.0	0.0	0.0	0.0%	0.0%	0.0%	NA	NA

Scoring:

- 0 – Not feasible. Criterion cannot be met by this alternative and removes the alternative from further consideration.
- 1 – Feasible but difficult. Criterion represents a significant barrier to successful implementation but does not eliminate it from consideration.
- 2 – Feasible. Criterion can be met by the alternative.
- 3 – Very Feasible. Criterion can be easily met by the alternative

APPENDIX B

**PRELIMINARY OPINION OF
TOTAL ESTIMATED CAPITAL COST
FOR BACKUP INTAKE AND RESERVOIR ON
TRIBUTARY OF ELK RIVER (OPTION A1)**

*Regional Intergovernmental Council
SWPP - Clay Roane PSD*

Item	Description	Unit	Quantity	Unit Price	Estimated Cost
1	Mobilization and Demobilization (Limited to 10% of Total Bid)	LS	1	\$ 39,000.00	\$ 39,000.00
2	Construction Layout Stakes (Limited to 5% of Total Bid)	LS	1	\$ 19,500.00	\$ 19,500.00
3	Quality Control (Limited to 3% of the Total)	LS	1	\$ 11,500.00	\$ 11,500.00
4	Site Preparation (Limited to 10% of Total Bid)	LS	1	\$ 39,000.00	\$ 39,000.00
5	Access Road	LF	4,600	\$ 17.50	\$ 80,500.00
6	Silt Fence	LF	150	\$ 1.20	\$ 180.00
7	Stabilized Construction Entrance	EA	1	\$ 2,000.00	\$ 2,000.00
8	Revegetation	SY	10,890	\$ 0.75	\$ 8,167.50
9	Principal Spillway Riser	EA	1	\$ 3,500.00	\$ 3,500.00
10	Emergency Spillway	CY	35	\$ 86.80	\$ 3,038.00
11	Temporary Stream Crossing	EA	1	\$ 1,000.00	\$ 1,000.00
12	Clearing & Grubbing	AC	1	\$ 11,275.00	\$ 11,275.00
13	Compaction	CY	3,670	\$ 1.65	\$ 6,055.50
14	Fill Hauling	CY	3,670	\$ 6.75	\$ 24,772.50
15	Geotextile Soil Stabilization	SY	2,150	\$ 2.45	\$ 5,267.50
16	Riprap	CY	18.5	\$ 62.50	\$ 1,156.25
17	Pond Leak Detection Sump	EA	1	\$ 10,000.00	\$ 10,000.00
18	Pond 12" Outlet Pipe - HDPE	LF	170	\$ 37.00	\$ 6,290.00
19	Chain Link Fence 8' high	LF	750	\$ 45.00	\$ 33,750.00
20	8' Double Swing Gate, 12' Opening	EA	1	\$ 1,825.00	\$ 1,825.00
21	NPDES Sign	EA	1	\$ 930.00	\$ 930.00
22	8-inch SDR 21 HDPE Gravity Raw Water Line	LF	8,360	\$ 50.00	\$ 418,000.00
23	16-inch Steel Casing, Open Cut Roadway Crossing	LF	25	\$ 90.00	\$ 2,250.00
24	DOH Type 'A' Trench	LF	40	\$ 75.00	\$ 3,000.00
25	8-inch SDR 21 HDPE 90° Bend	EA	2	\$ 300.00	\$ 600.00
26	8" M. J. Gate Valves	EA	1	\$ 1,100.00	\$ 1,100.00
27	Valve Vault and Piping Inside	EA	1	\$ 16,700.00	\$ 16,700.00
28	Manhole	EA	17	\$ 3,000.00	\$ 51,000.00
29	Thrust Block for 8" Pipe	EA	2	\$ 100.00	\$ 200.00
	<i>Subtotal:</i>				\$ 801,557.25
	<i>Contingency (20%):</i>				\$ 160,311.45
	<i>Soft Costs (30%):</i>				\$ 288,560.61
	TOTAL:				\$ 1,250,429.31
	SAY:				\$ 1,300,000

- Notes: 1. Soft costs include engineering, legal, accounting, administrative, land acquisition and other non-construction items. Regulatory agency requirements (i.e., environmental studies) could add to soft cost.
2. If a tributary closer to the WTP could be utilized, the reduction in linear feet of 8-inch water line could yield significant savings.

**PRELIMINARY OPINION OF
TOTAL ESTIMATED CAPITAL COST FOR
RAW WATER STORAGE (OPTION B1)**

*Regional Intergovernmental Council
SWPP - Clay Roane PSD*

Item	Description	Unit	Quantity	Unit Price	Estimated Cost
1	Mobilization/Insurance/Bonding	LS	1	\$ 40,000.00	\$ 40,000.00
2	300,000 Gallon Tank (including roof)	LS	1	\$ 350,000.00	\$ 350,000.00
3	Foundation	LS	1	\$ 60,000.00	\$ 60,000.00
4	Valve Vault/Piping	LS	1	\$ 14,000.00	\$ 14,000.00
5	Site Work (grading/stone)	LS	1	\$ 3,500.00	\$ 3,500.00
6	Connection to Existing Water Line	EA	1	\$ 2,500.00	\$ 2,500.00
7	8" DIP Class 50 Water Line	LF	250	\$ 60.00	\$ 15,000.00
	Subtotal:				\$ 485,000.00
	Contingency (20%):				\$ 97,000.00
	Soft Costs (30%):				\$ 174,600.00
	TOTAL:				\$ 756,600.00
	SAY:				\$ 800,000

- Notes: 1. Soft costs include engineering, legal, accounting, administrative, land acquisition and other non-construction items.
2. Additional monies would be required if telemetry/controls or mixer required.
3. The unit price of water line includes valving and restrainers.
4. Assumes no electrical, fence, or gate since the tank site is next to the WTP.

**PRELIMINARY OPINION OF
TOTAL ESTIMATED CAPITAL COST
FOR INTERCONNECTION WITH TOWN OF CLAY
WATER DEPARTMENT (OPTION C2)**

*Regional Intergovernmental Council
SWPP - Clay Roane Public Service District*

Item	Description	Unit	Quantity	Unit Price	Estimated Cost
1	Connection to Existing Water Line	EA	2	\$ 5,000.00	\$ 10,000.00
2	Emergency Bypass Booster Station	LS	1	\$ 75,000.00	\$ 75,000.00
3	Emergency Bypass Pressure Reducing Valve	LS	1	\$ 20,000.00	\$ 20,000.00
	Subtotal:				\$ 105,000.00
	Contingency (20%):				\$ 21,000.00
	Soft Costs (30%):				\$ 37,800.00
	TOTAL:				\$ 163,800.00
	SAY:				\$ 200,000

- Notes:
1. Connection to existing water line includes connections to 6-inch water line along State Route 4 to allow emergency bypass booster station to "straddle" existing PRV. Costs include gate valves and limited amount of 6-inch ductile iron piping.
 2. Emergency bypass PRV assumes 2-inch PRV, tapped and installed inside Hooks booster station.
 3. Cost of emergency bypass booster station contemplates manual operation. Addition of controls would increase cost.
 4. Soft costs include engineering, legal, accounting, administrative, land acquisition, and other non-construction costs.

APPENDIX C

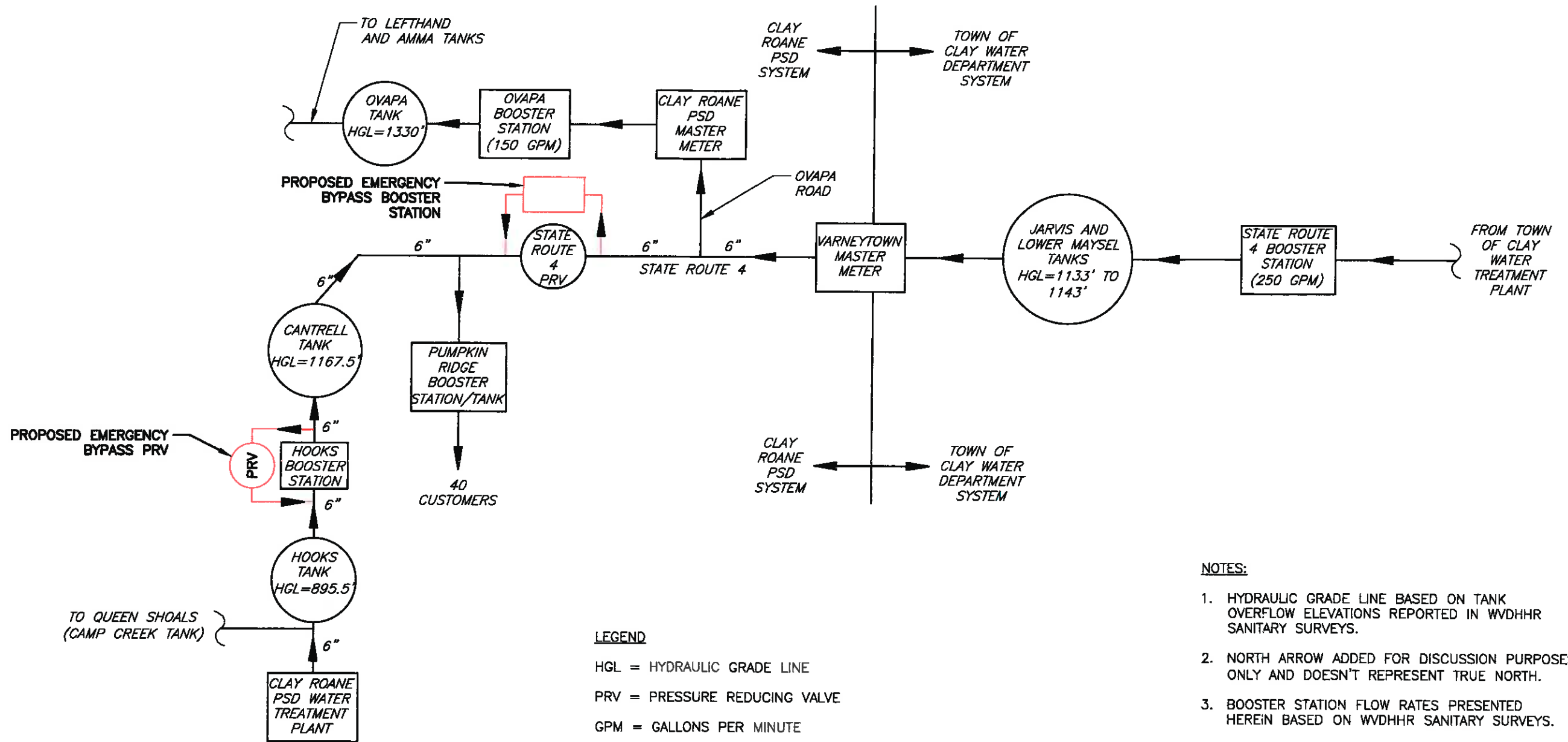

LEGEND
 HGL = HYDRAULIC GRADE LINE
 PRV = PRESSURE REDUCING VALVE
 GPM = GALLONS PER MINUTE

- NOTES:**
1. HYDRAULIC GRADE LINE BASED ON TANK OVERFLOW ELEVATIONS REPORTED IN WVDHHR SANITARY SURVEYS.
 2. NORTH ARROW ADDED FOR DISCUSSION PURPOSES ONLY AND DOESN'T REPRESENT TRUE NORTH.
 3. BOOSTER STATION FLOW RATES PRESENTED HEREIN BASED ON WVDHHR SANITARY SURVEYS.
 4. "RED" FEATURES ARE PROPOSED UPGRADES.

ARCEL FILES:
 IMAGE Files:
 File: S:\C3D-Proj-YR\2015\15-0023\PHASE 030\15-0023-030-01.dwg
 Plot Date/Time: Aug 26, 2015 3:56pm
 Plotted By: beleedy

PROJECT #: 15-0023-030 FILENAME: 15-0023-030-01



POTESTA & ASSOCIATES, INC.
 ENGINEERS AND ENVIRONMENTAL CONSULTANTS

7012 MacCorkle Ave. SE, Charleston, WV 25304
 TEL: (304) 342-1400 FAX: (304) 343-9031
 E-Mail Address: potesta@potesta.com

Project
SCHEMATIC OF EXISTING SYSTEMS IN THE VICINITY OF CLAY ROANE PSD / TOWN OF CLAY WATER DEPARTMENT INTERCONNECTION LOCATION AND PROPOSED INTERCONNECTION UPGRADES

Scale NOT TO SCALE
 Date JULY 2015

Dwg. No.
FIGURE 1

APPENDIX D



Be Right™

Quotation

Quote Number: 100085723v2

Use quote number at time of order to ensure that you receive prices quoted

Hach Company
 PO Box 608
 Loveland, CO 80539-0608
 Phone: (800) 227-4224
 Email: quotes@hach.com
 Website: www.hach.com

Quote Date: 06/05/15

Quote Expiration: 08/04/15

POTESTA & ASSOCIATES, INC.
 7012 MACCORKLE AVE SE
 CHARLESTON, WV 25304

Name: Angela K. Pugh
 Phone: (304)342-1400
 Email: akpugh@potesta.com

Customer Account Number: 829990

Sales Contact: Rocky Bragg Email: rbragg@hach.com Phone: 800-227-4224

PRICING QUOTATION

Line	Part Number	Description	Qty	Extended Price
1	580800	Back panel/Trough/Level (required)	1	4,500.00
2	LXV400.99.1A082	MODULE, PROBE (6 SNSR), SC1000	1	1,344.00
3	YAB018	CARD, INTERNAL SC1000, 4 mA INPUTS	1	908.00
4	LXV402.99.00002	db MODULE, DISPLAY W/O GSM, SC1000	1	2,770.00
5	9020000	ASSY, PROBE, LDO MODEL 2, HACH	1	1,804.00
6	DRD1R5-WDMP	ORP Sensor, Ryton, WDMP Mounting	1	904.00
7	DPD1R1-WDMP	pH Sensor, Ryton, WDMP Mounting	1	840.00
8	LXV423.99.10000	SOLITAX t-line sc/immersion probe 0.001-4000 NTU; wiper:PVC	1	3,474.00
9	LXV418.99.50002	db UVAS sc PROBE, 5mm	1	17,305.00
10	WRTUPGWDMP	Comprehensive warranty upgrade includes: Instrument start-up, all parts, labor, and travel for on-site repairs, 4 on-site calibrations per year, factory recommended maintenance (including required parts), unlimited technical support calls, and free firmware updates. On-site response for "down" instrument repairs is typically 3 business days. Standard business hours are 8am-5pm M-F local time, excluding holidays. Please see service terms and conditions for additional details on our service plans, and to ensure you have an opportunity to review our environmental and safety requirements.	1	1,916.00
11	WRTUPGSC1000	Comprehensive warranty upgrade includes: Instrument start-up, all parts, labor, and travel for on-site repairs, 1 on-site factory recommended maintenance (including required parts), unlimited technical support calls, and free firmware updates. On-site response for "down" instrument repairs is typically 3 business days. Standard business hours are 8am-5pm M-F local time, excluding holidays. Please see service terms and conditions for additional details on our service plans, and to ensure you have an opportunity to review our environmental and safety requirements.	1	233.00
12	WRTUPGLDO2	Comprehensive warranty upgrade includes: Instrument start-up, all parts, labor, and travel for on-site repairs, 1 on-site visit for cleaning, inspection, air calibration, and factory recommended maintenance (including required parts), unlimited technical support calls, and free firmware updates. On-site response for "down" instrument repairs is typically 3 business days. Standard business hours are 8am-5pm M-F local time, excluding holidays. Please see service terms and conditions for additional details on our service plans, and to ensure you have an opportunity to review our	1	440.00

Line	Part Number	Description	Qty	Extended Price
		environmental and safety requirements.		
13	WRTUPGGLPHORP	Comprehensive warranty upgrade includes: instrument start-up, all parts, labor, and travel for on-site repairs, 1 on-site calibration per year, factory recommended maintenance (including required parts), unlimited technical support calls, and free firmware updates. On-site response for "down" instrument repairs is typically 3 business days. Standard business hours are 8am-5pm M-F local time, excluding holidays. Please see service terms and conditions for additional details on our service plans, and to ensure you have an opportunity to review our environmental and safety requirements.	2	442.00
14	WRTUPGSOLITAX	Comprehensive warranty upgrade includes: instrument start-up, all parts, labor, and travel for on-site repairs, 2 on-site calibrations per year, factory recommended maintenance (including required parts), unlimited technical support calls, and free firmware updates. On-site response for "down" instrument repairs is typically 3 business days. Standard business hours are 8am-5pm M-F local time, excluding holidays. Please see service terms and conditions for additional details on our service plans, and to ensure you have an opportunity to review our environmental and safety requirements.	1	941.00
15	WRTUPGUVAS	Comprehensive warranty upgrade includes: instrument start-up, all parts, labor, and travel for on-site repairs, 2 on-site calibrations per year, factory recommended maintenance (including required parts), unlimited technical support calls, and free firmware updates. On-site response for "down" instrument repairs is typically 3 business days. Standard business hours are 8am-5pm M-F local time, excluding holidays. Please see service terms and conditions for additional details on our service plans, and to ensure you have an opportunity to review our environmental and safety requirements.	1	1,028.00
Grand Total			\$	38,849.00

TERMS OF SALE

Freight: Ground Prepay and Add

FOB: Hach's facility

All purchases of Hach Company products and/or services are expressly and without limitation subject to Hach Company's Terms & Conditions of Sale ("Hach TCS"), incorporated herein by reference and published on Hach Company's website at www.hach.com/terms. Hach TCS are contained directly and/or by reference in Hach's offer, order acknowledgment, and invoice documents. The first of the following acts constitutes an acceptance of Hach's offer and not a counteroffer and creates a contract of sale "Contract" in accordance with the Hach TCS: (i)

Buyer's issuance of a purchase order document against Hach's offer; (ii) acknowledgement of Buyer's order by Hach; or (iii) commencement of any performance by Hach pursuant to Buyer's order. Provisions contained in Buyer's purchase documents (including electronic commerce interfaces) that materially alter, add to or subtract from the provisions of the Hach TCS are not part of the Contract.

Due to international regulations, a U.S. Department of Commerce Export License may be required. Hach reserves the right to approve specific shipping agents. Wooden boxes suitable for ocean shipment are extra. Specify final destination to ensure proper documentation and packing suitable for international transport. In addition, Hach may require: 1). A statement of intended end-use; 2). Certification that the intended end-use does not relate to proliferation of weapons of mass destruction (prohibited nuclear end use, chemical / biological weapons, missile technology); and 3). Certification that the goods will not be diverted contrary to U.S. law.

ORDER TERMS:

Terms are Subject to Credit Review
Please reference the quotation number on your purchase order.
Sales tax is not included. Applicable sales tax will be added to the invoice based on the U.S. destination, if applicable provide a resale/exemption certificate.
Shipments will be prepaid and added to invoices unless otherwise specified.
Equipment quoted operates with standard U.S. supply voltage.
Hach standard terms and conditions apply to all sales.
Additional terms and conditions apply to orders for service partnerships.
Prices do not include delivery of product. Reference attached Freight Charge Schedule and Collect Handling Fees.
Standard lead time is 30 days.
This Quote is good for a one time purchase.

Sales Contact:

Name: Rocky Bragg
Title: Regional Sales Manager
Phone: 800-227-4224
Email: rbragg@hach.com

Prepared By:

Name: Rachel Le Blanc
Title: Field Sales Support Specialist II
Phone: 800-227-4224 X 6274
Email: rleblan@hach.com



Be Right™

Quotation Addendum

HACH COMPANY

Headquarters
P.O. Box 389
5600 Lindbergh Drive
Loveland, CO 80539-0389

Purchase Orders
PO Box 608
Loveland, CO 80539-0608

WebSite: www.hach.com

U.S.A.

Phone: 800-227-4224
Fax: 970-669-2932
E-Mail: orders@hach.com
quotes@hach.com
techhelp@hach.com

Export

Phone: 970-669-3050
Fax: 970-461-3939
Email: intl@hach.com

Remittance

2207 Collections Center Drive
Chicago, IL 60693

Wire Transfers

Bank of America
231 S. LaSalle St.
Chicago, IL 60604
Account: 8765602385
Routing (ABA): 071000039

ADVANTAGES OF WORKING WITH HACH

<u>Technical Support</u>	<u>SIRR Delivery Program</u>	<u>Hach WarrantyPlus™ Upgrade</u>
<i>Provides post-sale instrumentation and application support</i> <ul style="list-style-type: none"> ✓ Hach's highly skilled Technical Support staff is dedicated to helping you resolve technical issues before, during and after the sale. ✓ Available via phone, e-mail, or live online chat at Hach.com! ✓ Toll-free phone: 800-227-4224 ✓ E-mail: techhelp@hach.com <p>www.Hach.com</p>	<i>The Scheduled Inventory Reagent Replacement (SIRR) Program offers an uninterrupted supply of reagents</i> <ul style="list-style-type: none"> ✓ Lower inventory costs and fresh supplies ✓ Reduced paperwork – one purchase order for the entire year ✓ Automatic shipments on your schedule ✓ Easier budgeting <p>www.Hach.com/sirr</p>	<i>Instrument Protection and Service</i> <ul style="list-style-type: none"> ✓ Savings of more than 20% versus a "pay as you go" approach ✓ Freedom from maintenance ✓ Worry-free compliance with Hach's certification ✓ Fixed maintenance budget for the entire year <p>www.Hach.com/warrantyplus</p>

ADVANTAGES OF SIMPLIFIED FREIGHT

<u>Safe & Fast Delivery</u>	<u>Save Time – Less Hassle</u>	<u>Save Money</u>
<ul style="list-style-type: none"> ✓ Receive tracking numbers on your order acknowledgement ✓ Hach will assist with claims if an order is lost or damaged in shipment 	<ul style="list-style-type: none"> ✓ No need to set up deliveries for orders or to schedule pickup ✓ Hach ships simplified freight orders as the product is available at no additional cost 	<ul style="list-style-type: none"> ✓ No additional invoice to process – save on time and administrative costs ✓ Only pay shipping once, even if multiple shipments are required

STANDARD SIMPLIFIED FREIGHT CHARGES ^{1, 2, 3}						Collect ⁴ Handling Fee Effective 8/16/2014
Total Price of Merchandise Ordered	Standard Surface (Mainland USA)	Second Day Delivery (Mainland USA)	Next Day Delivery (Mainland USA)	Second Day Delivery (Alaska & Hawaii)	Next Day Delivery (Alaska & Hawaii)	
\$0.00 - \$49.99	\$11.99	\$29.99	\$54.99	\$44.95	\$85.45	\$7.79
\$50.00 - \$199.99	\$17.79	\$52.45	\$98.97	\$71.64	\$136.19	\$7.99
\$200.00 - \$449.99	\$30.89	\$79.43	\$161.79	\$100.23	\$195.06	\$8.47
\$450.00 - \$749.99	\$41.67	\$108.95	\$216.68	\$136.20	\$263.73	\$8.89
\$750.00 - \$999.99	\$52.77	\$114.40	\$239.39	\$141.65	\$267.00	\$9.17
\$1,000.00 - \$2,249.99	\$66.39	\$130.75	\$255.01	\$154.73	\$307.33	\$9.49
\$2,250.00 - \$4,999.99	\$79.47	\$174.35	\$294.25	\$181.98	\$336.76	\$11.32
\$5,000.00 - \$9,999.99	\$112.79	\$201.60	\$338.94	\$213.59	\$365.10	\$16.83
Over \$10,000	2% of Net Order Value	4% of Net Order Value	6% of Net Order Value	4% of Net Order Value	6% of Net Order Value	\$29.49

- 1 Freight charges shown are only applicable to orders billing and shipping to U.S. destinations. Freight charges will be prepaid and added to invoice. Freight for the Reagent Delivery Program is charged on each shipment release and is based on the total price of each shipment release. Freight charges are subject to change without notice.
- 2 Additional freight charges will be applied to orders containing bulky and/or especially heavy orders. Refrigerated and all weather Samplers do not qualify for simplified freight charges, and are considered heavy freight. Dissolved Oxygen Sensors can be damaged if exposed to temps below freezing, causing sensor failure. Must be shipped over night or 2nd day air during the cold weather months.
- 3 Orders shipping to Alaska or Hawaii: Additional freight charges may be applied at time of order processing. Second Day and Next Day delivery is not available to all destinations.
- 4 Hach Company will assess a collect handling fee on orders with collect freight terms. This handling fee covers the additional costs that Hach Company incurs from processing and managing collect shipments.

SALES TAX

Sales Tax is not included in the attached quotation. Applicable sales and usage taxes will be added to your invoice, at the time of order, based on U.S. destination of goods, unless a valid resale/exemption certificate for destination state is provided to the above address or fax number, attention of the Tax Dept.

TERMS & CONDITIONS OF SALE FOR HACH COMPANY PRODUCTS AND SERVICES

This document sets forth the Terms & Conditions of Sale for goods manufactured and/or supplied, and services provided, by Hach Company of Loveland, Colorado ("Hach") and sold to the original purchaser thereof ("Buyer"). Unless otherwise specifically stated herein, the term "Hach" includes only Hach Company and none of its affiliates. Unless otherwise specifically stated in a previously-executed written purchase agreement signed by authorized representatives of Hach and Buyer, these Terms & Conditions of Sale establish the rights, obligations and remedies of Hach and Buyer which apply to this offer and any resulting order or contract for the sale of Hach's goods and/or services ("Products").

1. APPLICABLE TERMS & CONDITIONS: These Terms & Conditions of Sale are contained directly and/or by reference in Hach's offer, order acknowledgment, and invoice documents. The first of the following acts constitutes an acceptance of Hach's offer and not a counteroffer and creates a contract of sale ("Contract") in accordance with these Terms & Conditions: (i) Buyer's issuance of a purchase order document against Hach's offer; (ii) acknowledgement of Buyer's order by Hach; or (iii) commencement of any performance by Hach pursuant to Buyer's order. Provisions contained in Buyer's purchase documents (including electronic commerce interfaces) that materially alter, add to or subtract from the provisions of these Terms & Conditions of Sale are not a part of the Contract.

2. CANCELLATION: Buyer may cancel goods orders subject to fair charges for Hach's expenses including handling, inspection, restocking, freight and invoicing charges as applicable, provided that Buyer returns such goods to Hach at Buyer's expense within 30 days of delivery and in the same condition as received. Buyer may cancel service orders on ninety (90) day's prior written notice and refunds will be prorated based on the duration of the service plan. Inspections and re-statement fees may apply upon cancellation or expiration of service programs. Seller may cancel all or part of any order prior to delivery without liability if the order includes any Products that Seller determines may not comply with export, safety, local certification, or other applicable compliance requirements.

3. DELIVERY: Delivery will be accomplished FCA Hach's facility located in Ames, Iowa or Loveland, Colorado, United States (Incoterms 2010). For orders having a final destination within the U.S., legal title and risk of loss or damage pass to Buyer upon transfer to the first carrier. For orders having a final destination outside the U.S., legal title and risk of loss or damage pass to Buyer when the Products enter international waters or airspace or cross an international frontier. Hach will use commercially reasonable efforts to deliver the Products ordered herein within the time specified on the face of this Contract or, if no time is specified, within Hach's normal lead-time necessary for Hach to deliver the Products sold hereunder. Upon prior agreement with Buyer and for an additional charge, Hach will deliver the Products on an expedited basis. Standard service delivery hours are 8 am - 5 pm Monday through Friday, excluding holidays.

4. INSPECTION: Buyer will promptly inspect and accept any Products delivered pursuant to this Contract after receipt of such Products. In the event the Products do not conform to any applicable specifications, Buyer will promptly notify Hach of such nonconformance in writing. Hach will have a reasonable opportunity to repair or replace the nonconforming product at its option. Buyer will be deemed to have accepted any Products delivered hereunder and to have waived any such nonconformance in the event such a written notification is not received by Hach within thirty (30) days of delivery.

5. PRICES & ORDER SIZES: All prices are in U.S. dollars and are based on delivery as stated above. Prices do not include any charges for services such as insurance; brokerage fees; sales, use, inventory or excise taxes; import or export duties; special financing fees; VAT, income or royalty taxes imposed outside the U.S.; consular fees; special permits or licenses; or other charges imposed upon the production, sale, distribution, or delivery of Products. Buyer will either pay any and all such charges or provide Hach with acceptable exemption certificates, which obligation survives performance under this Contract. Hach reserves the right to establish minimum order sizes and will advise Buyer accordingly.

6. PAYMENTS: All payments must be made in U.S. dollars. For internet orders, the purchase price is due at the time and manner set forth at www.hach.com. Invoices for all other orders are due and payable NET 30 DAYS from date of the invoice without regard to delays for inspection or transportation, with payments to be made by check to Hach at the above address or by wire transfer to the account stated on the front of Hach's invoice, or for customers with no established credit, Hach may require cash or credit card payment in advance of delivery. In the event payments are not made or not made in a timely manner, Hach may, in addition to all other remedies provided at law, either: (a) declare Buyer's performance in breach and terminate this Contract for default; (b) withhold future shipments until delinquent payments are made; (c) deliver future shipments on a cash-with-order or cash-in-advance basis even after the delinquency is cured; (d) charge interest on the delinquency at a rate of 1-1/2% per month or the maximum rate permitted by law, if lower, for each month or part thereof of delinquency in payment plus applicable storage charges and/or inventory carrying charges; (e) repossess the Products for which payment has not been made; (f) recover all costs of collection

including reasonable attorney's fees; or (g) combine any of the above rights and remedies as is practicable and permitted by law. Buyer is prohibited from setting off any and all monies owed under this from any other sums, whether liquidated or not, that are or may be due Buyer, which arise out of a different transaction with Hach or any of its affiliates. Should Buyer's financial responsibility become unsatisfactory to Hach in its reasonable discretion, Hach may require cash payment or other security. If Buyer fails to meet these requirements, Hach may treat such failure as reasonable grounds for repudiation of this Contract, in which case reasonable cancellation charges shall be due Hach. Buyer grants Hach a security interest in the Products to secure payment in full, which payment releases the security interest but only if such payments could not be considered an avoidable transfer under the U.S. Bankruptcy Code or other applicable laws. Buyer's insolvency, bankruptcy, assignment for the benefit of creditors, or dissolution or termination of the existence of Buyer, constitutes a default under this Contract and affords Hach all the remedies of a secured party under the U.C.C., as well as the remedies stated above for late payment or non-payment.

7. LIMITED WARRANTY: Hach warrants that Products sold hereunder will be free from defects in material and workmanship and will, when used in accordance with the manufacturer's operating and maintenance instructions, conform to any express written warranty pertaining to the specific goods purchased, which for most Hach Instruments is for a period of twelve (12) months from delivery. Hach warrants that services furnished hereunder will be free from defects in workmanship for a period of ninety (90) days from the completion of the services. Parts provided by Hach in the performance of services may be new or refurbished parts functioning equivalent to new parts. Any non-functioning parts that are repaired by Hach shall become the property of Hach. No warranties are extended to consumable items such as, without limitation, reagents, batteries, mercury cells, and light bulbs. All other guarantees, warranties, conditions and representations, either express or implied, whether arising under any statute, law, commercial usage or otherwise, including implied warranties of merchantability and fitness for a particular purpose, are hereby excluded. The sole remedy for Products not meeting this Limited Warranty is replacement, credit or refund of the purchase price. This remedy will not be deemed to have failed of its essential purpose so long as Hach is willing to provide such replacement, credit or refund.

8. INDEMNIFICATION: Indemnification applies to a party and to such party's successors-in-interest, assignees, affiliates, directors, officers, and employees ("Indemnified Parties"). Hach is responsible for and will defend, indemnify and hold harmless the Buyer Indemnified Parties against all losses, claims, expenses or damages which may result from accident, injury, damage, or death due to Hach's breach of the Limited Warranty. This indemnification is provided on the condition that the Buyer is likewise responsible for and will defend, indemnify and hold harmless the Hach Indemnified Parties against all losses, claims, expenses or damages which may result from accident, injury, damage, or death due to the negligence or misuse or misapplication of any goods or services by the Buyer or any third party affiliated or in privity with Buyer.

9. PATENT PROTECTION: Subject to all limitations of liability provided herein, Hach will, with respect to any Products of Hach's design or manufacture, indemnify Buyer from any and all damages and costs as finally determined by a court of competent jurisdiction in any suit for infringement of any U.S. patent (or European patent for Products that Hach sells to Buyer for end use in a member state of the E.U.) that has issued as of the delivery date, solely by reason of the sale or normal use of any Products sold to Buyer hereunder and from reasonable expenses incurred by Buyer in defense of such suit if Hach does not undertake the defense thereof, provided that Buyer promptly notifies Hach of such suit and offers Hach either (i) full and exclusive control of the defense of such suit when Products of Hach only are involved, or (ii) the right to participate in the defense of such suit when products other than those of Hach are also involved. Hach's warranty as to use patents only applies to infringement arising solely out of the inherent operation of the Products according to their applications as envisioned by Hach's specifications. In case the Products are in such suit held to constitute infringement and the use of the Products is enjoined, Hach will, at its own expense and at its option, either procure for Buyer the right to continue using such Products or replace them with non-infringing products, or modify them so they become non-infringing, or remove the Products and refund the purchase price (prorated for depreciation) and the transportation costs thereof. The foregoing states the entire liability of Hach for patent infringement by the Products. Further, to the same extent as set forth in Hach's above obligation to Buyer, Buyer agrees to defend, indemnify and hold harmless Hach for patent infringement related to (x) any goods manufactured to the Buyer's design, (y) services provided in accordance with the Buyer's instructions, or (z) Hach's Products when used in combination with any other devices, parts or software not provided by Hach hereunder.

10. TRADEMARKS AND OTHER LABELS: Buyer agrees not to remove or alter any indicia of manufacturing origin or patent numbers contained on or within the Products, including without limitation the serial numbers or trademarks on nameplates or cast, molded or machined components.



11. **SOFTWARE.** All licenses to Hach's separately-provided software products are subject to the separate software license agreement(s) accompanying the software media. In the absence of such terms and for all other software, Hach grants Buyer only a personal, non-exclusive license to access and use the software provided by Hach with Products purchased hereunder solely as necessary for Buyer to enjoy the benefit of the Products. A portion of the software may contain or consist of open source software, which Buyer may use under the terms and conditions of the specific license under which the open source software is distributed. Buyer agrees that it will be bound by any and all such license agreements. Title to software remains with the applicable licensor(s).

12. **PROPRIETARY INFORMATION; PRIVACY:** "Proprietary Information" means any information, technical data or know-how in whatever form, whether documented, contained in machine readable or physical components, mask works or artwork, or otherwise, which Hach considers proprietary, including but not limited to service and maintenance manuals. Buyer and its customers, employees and agents will keep confidential all such Proprietary Information obtained directly or indirectly from Hach and will not transfer or disclose it without Hach's prior written consent, or use it for the manufacture, procurement, servicing or calibration of Products or any similar products, or cause such products to be manufactured, serviced or calibrated by or procured from any other source, or reproduce or otherwise appropriate it. All such Proprietary Information remains Hach's property. No right or license is granted to Buyer or its customers, employees or agents, expressly or by implication, with respect to the Proprietary Information or any patent right or other proprietary right of Hach, except for the limited use licenses implied by law. Hach will manage Customer's information and personal data in accordance with its Privacy Policy, located at <http://www.hach.com/privacypolicy>.

13. **CHANGES AND ADDITIONAL CHARGES:** Hach reserves the right to make design changes or improvements to any products of the same general class as Products being delivered hereunder without liability or obligation to incorporate such changes or improvements to Products ordered by Buyer unless agreed upon in writing before the Products' delivery date. Services which must be performed as a result of any of the following conditions are subject to additional charges for labor, travel and parts: (a) equipment alterations not authorized in writing by Hach; (b) damage resulting from improper use or handling, accident, neglect, power surge, or operation in an environment or manner in which the instrument is not designed to operate or is not in accordance with Hach's operating manuals; (c) the use of parts or accessories not provided by Hach; (d) damage resulting from acts of war, terrorism or nature; (e) services outside standard business hours; (f) site prework not complete per proposal; or (g) any repairs required to ensure equipment meets manufacturer's specifications upon activation of a service agreement.

14. **SITE ACCESS / PREPARATION / WORKER SAFETY / ENVIRONMENTAL COMPLIANCE:** In connection with services provided by Hach, Buyer agrees to permit prompt access to equipment. Buyer assumes full responsibility to back-up or otherwise protect its data against loss, damage or destruction before services are performed. Buyer is the operator and in full control of its premises, including those areas where Hach employees or contractors are performing service, repair and maintenance activities. Buyer will ensure that all necessary measures are taken for safety and security of working conditions, sites and installations during the performance of services. Buyer is the generator of any resulting wastes, including without limitation hazardous wastes. Buyer is solely responsible to arrange for the disposal of any wastes at its own expense. Buyer will, at its own expense, provide Hach employees and contractors working on Buyer's premises with all information and training required under applicable safety compliance regulations and Buyer's policies. If the instrument to be serviced is in a Confined Space, as that term is defined under OSHA regulations, Buyer is solely responsible to make it available to be serviced in an unconfined space. Hach service technicians will not work in Confined Spaces. In the event that a Buyer requires Hach employees or contractors to attend safety or compliance training programs provided by Buyer, Buyer will pay Hach the standard hourly rate and expense reimbursement for such training attended. The attendance at or completion of such training does not create or expand any warranty or obligation of Hach and does not serve to alter, amend, limit or supersede any part of this Contract.

15. **LIMITATIONS ON USE:** Buyer will not use any Products for any purpose other than those identified in Hach's catalogs and literature as intended uses. Unless Hach has advised the Buyer in writing, in no event will Buyer use any Products in drugs, food additives, food or cosmetics, or medical applications for humans or animals. In no event will Buyer use in any application any Product that requires FDA 510(k) clearance unless and only to the extent the Product has such clearance. Any warranty granted by Hach is void if any goods covered by such warranty are used for any purpose not permitted hereunder.

16. **EXPORT AND IMPORT LICENSES AND COMPLIANCE WITH LAWS:** Unless otherwise specified in this Contract, Buyer is responsible for obtaining any required export or import licenses. Hach represents that all Products delivered hereunder will be produced and supplied in compliance with all applicable laws and regulations. Buyer will comply with all laws and regulations applicable to the installation or use of all Products, including applicable import and export control laws and regulations of the U.S., E.U. and any other country having proper jurisdiction, and will obtain all necessary export licenses in connection with any subsequent export, re-export, transfer and use of all Products and technology delivered hereunder. Buyer will not sell, transfer, export or re-export any Hach

Products or technology for use in activities which involve the design, development, production, use or stockpiling of nuclear, chemical or biological weapons or missiles, nor use Hach Products or technology in any facility which engages in activities relating to such weapons. Buyer will comply with all local, national, and other laws of all jurisdictions globally relating to anti-corruption, bribery, extortion, kickbacks, or similar matters which are applicable to Buyer's business activities in connection with this Contract, including but not limited to the U.S. Foreign Corrupt Practices Act of 1977, as amended (the "FCPA"). Buyer agrees that no payment of money or provision of anything of value will be offered, promised, paid or transferred, directly or indirectly, by any person or entity, to any government official, government employee, or employee of any company owned in part by a government, political party, political party official, or candidate for any government office or political party office to induce such organizations or persons to use their authority or influence to obtain or retain an improper business advantage for Buyer or for Hach, or which otherwise constitute or have the purpose or effect of public or commercial bribery, acceptance of or acquiescence in extortion, kickbacks or other unlawful or improper means of obtaining business or any improper advantage, with respect to any of Buyer's activities related to this Contract. Hach asks Buyer to "Speak Up!" if aware of any violation of law, regulation or our Standards of Conduct ("SOC") in relation to this Contract. See <http://danaher.com/integrity-and-compliance> and www.danaherintegrity.com for a copy of the SOC and for access to our Helpline portal.

17. **FORCE MAJEURE:** Hach is excused from performance of its obligations under this Contract to the extent caused by acts or omissions that are beyond its control of, including but not limited to Government embargoes, blockages, seizures or freeze of assets, delays or refusals to grant an export or import license or the suspension or revocation thereof, or any other acts of any Government; fires, floods, severe weather conditions, or any other acts of God; quarantines; labor strikes or lockouts; riots; strife; insurrections; civil disobedience or acts of criminals or terrorists; war; material shortages or delays in deliveries to Hach by third parties. In the event of the existence of any force majeure circumstances, the period of time for delivery, payment terms and payments under any letters of credit will be extended for a period of time equal to the period of delay. If the force majeure circumstances extend for six months, Hach may, at its option, terminate this Contract without penalty and without being deemed in default or in breach thereof.

18. **NON ASSIGNMENT AND WAIVER:** Buyer will not transfer or assign this Contract or any rights or interests hereunder without Hach's prior written consent. Failure of either party to insist upon strict performance of any provision of this Contract, or to exercise any right or privilege contained herein, or the waiver of any breach of the terms or conditions of this Contract will not be construed as thereafter waiving any such terms, conditions, rights, or privileges, and the same will continue and remain in force and effect as if no waiver had occurred.

19. **LIMITATION OF LIABILITY:** None of the Hach Indemnified Parties will be liable to Buyer under any circumstances for any special, treble, incidental or consequential damages, including without limitation, damage to or loss of property other than for the Products purchased hereunder; damages incurred in installation, repair or replacement; lost profits, revenue or opportunity; loss of use; losses resulting from or related to downtime of the products or inaccurate measurements or reporting; the cost of substitute products; or claims of Buyer's customers for such damages, howsoever caused, and whether based on warranty, contract, and/or tort (including negligence, strict liability or otherwise). The total liability of the Hach Indemnified Parties arising out of the performance or nonperformance hereunder or Hach's obligations in connection with the design, manufacture, sale, delivery, and/or use of Products will in no circumstance exceed in the aggregate a sum equal to twice the amount actually paid to Hach for Products delivered hereunder.

20. **APPLICABLE LAW AND DISPUTE RESOLUTION:** The construction, interpretation and performance hereof and all transactions hereunder shall be governed by the laws of the State of Colorado, without regard to its principles or laws regarding conflicts of laws. If any provision of this Contract violates any Federal, State or local statutes or regulations of any countries having jurisdiction of this transaction, or is illegal for any reason, said provision shall be self-deleting without affecting the validity of the remaining provisions. Unless otherwise specifically agreed upon in writing between Hach and Buyer, any dispute relating to this Contract which is not resolved by the parties shall be adjudicated in order of preference by a court of competent jurisdiction (i) in the State of Colorado, U.S.A. if Buyer has minimum contacts with Colorado and the U.S., (ii) elsewhere in the U.S. if Buyer has minimum contacts with the U.S. but not Colorado, or (iii) in a neutral location if Buyer does not have minimum contacts with the United States.

21. **ENTIRE AGREEMENT & MODIFICATION:** These Terms & Conditions of Sale constitute the entire agreement between the parties and supersede any prior agreements or representations, whether oral or written. No change to or modification of these Terms & Conditions shall be binding upon Hach unless in a written instrument specifically referencing that it is amending these Terms & Conditions of Sale and signed by an authorized representative of Hach. Hach rejects any additional or inconsistent Terms & Conditions of Sale offered by Buyer at any time, whether or not such terms or conditions materially alter the Terms & Conditions herein and irrespective of Hach's acceptance of Buyer's order for the described goods and services.



APPENDIX E. SUPPORTING DOCUMENTATION

Clay Roane PSD and Clay Municipal Water Protection Team Combined Meeting

May 17, 2016, 1:00 pm, Clay City Hall, 956 Main Street, Clay, WV

Attendees:

- Drema Thomas, Clay Municipal Water, Chief Operator
- Dwana Murphy, Clay Municipal Water, Operator
- Joe Coleman, Clay Municipal Water, Plant Maintenance and Town Recorder
- Crystal Hayes, Clay Roane PSD General Manager
- Robert Burdette, Clay Roane PDS Chief Operator
- Angie Rosser, West Virginia Rivers Coalition, Executive Director
- John Beckman, Tetra Tech

Opening remarks concerning Charleston Water Crisis and subsequent new legislation. Mentioned old source water plan developed by Potesta in 2010, and new contingency plan and feasibility study written by Potesta in 2015.

Added members to the protection team who were not able to attend the May 17 meeting. Added Mike Scott, Clay Volunteer Fire Department, Fire Chief; Heath Cliver, Clay County Health Department, Sanitarian; Brian Holcomb, Clay Roane PSD Board Chairman; Stacy King, Clay County EOS Director.

Reviewed protection watershed, zone of critical and peripheral concern maps. Maps were determined to be accurate. No changes were requested. There was an algae bloom on Sutton Lake in 2014. The Corps of Engineers warned Clay Municipal Water when the algae-affected water was released from the dam. Clay Roane PSD did not find out about the algae-affected water until a week after the event. No adverse effects to finished water were observed in either system. There have been no other potential contamination events in recent memory.

The 2012 derecho event knocked out electric power in Clay County for over a week. Both plants relied on diesel generators to keep the plants running. Clay Roane PSD had to rent generators. Both systems currently own their generators.

Discussed PSSCs and management strategies. Existing strategies in Table 9 were reviewed and found acceptable. Many private homes in the watershed on septic, and there is a sewage treatment plant above Clay Roane PSD. Highway traffic and oil/gas development were discussed. Vandalism is a minor problem. Fencing is a problem because high water pushes debris into chain link fences and washes them out.

Education strategies were discussed. Plant tours are impractical because of liability. Strong chemicals are stored at the plant and could be dangerous to children. Drinking water signs on roadways or near the intake were removed as a strategy. Operators expressed the opinion that the less people know about intake locations the better.

Made corrections to Contingency portion of source water protection plan. Hours each system could supply customers with stored water needed to be adjusted for both systems.

Both systems have an emergency response plan. Clay Municipal Water's plan was last updated in 2008.

Discussed need to inform public within 30 minutes of discovering potential contamination of source water. Both systems have a Facebook page that could be used during an emergency. Both systems rely on county 911 to broadcast alerts. Clay Roane PSD manager makes phone calls to affected customers.

Identified primary and secondary spokespeople for both systems.

Decided to hold a source water protection public meetings concurrent with Clay Municipal Water utility board meeting on June 9 at 5 pm, and Clay Roane PSD board meeting on June 9 at 6:30 pm.

Clay Roane PSD Source Water Protection Public Meeting

June 9, 2016, 6:30 pm, at water plant office, 1100 Elkhurst Road, Prociuous, WV

Attendees:

- Crystal Hayes, Clay Roane PSD (CRPSD)
- Merlin Shamblin, Roane County Commission
- David Grigsby, CRPSD Board
- Michael Taylor, CRPSD Board
- Susan Beard, CRPSD Board Chair
- Bill Shears, Amma Resident
- Vickey Shamblin, Roane County Resident
- William Stonestreet, CRPSD
- Braydon Crouch, George Washington H.S.
- John Beckman, Tetra Tech

Public meeting was held concurrently with regularly scheduled Clay Roane PSD board meeting. Meeting was open to the public and advertised in the newspaper and at the PSD office a week before.

Reviewed source water protection timeline. Discussed Charleston Water Crisis of 2014 and reasons for new source water protection legislation. Discussed update to Clay Roane PSD's 2010 plan, and incorporation of Potesta's recent contingency/feasibility study. Reviewed plan table of contents and sections. Noted that past source water protection activities once voluntary have now become mandatory.

Summarized potential significant sources: state Route 4 and 16 run close to Elk River – potential for vehicle accidents or toxic spills; some residences and facilities upstream of intake are on septic, home aeration units, or package plants – potential for sewage leaks to reach Elk River; and oil and gas development is common in the watershed – small spills associated with drilling are possible.

Summarized contingency plan alternatives: construct backup reservoir on one of several small creeks near water plant; interconnection with neighboring water systems (WVAW or Clay Municipal Water); increase treated water storage; and build raw water storage tank.

Discussed 30 minute public notification requirement. Noted Communication Plan in Appendix C with emergency contact information. Reviewed designated spokespeople for Clay Roane PSD.

Board member Grigsby mentioned that an interconnection with Spencer had been investigated in the past to have a backup water source located in a completely different watershed. Also mentioned that County governments were planning emergency drills and Clay Roane PSD was planning to participate.

Question about 5 and 10 hour time of travel estimates for zones of critical and peripheral concern. Clarification that the time of travel was time for a spill to initially reach the intake, not time for a spill to completely pass the intake. Calculations for length of time the intake should stay closed were not performed or taken into account in determining the zones of critical or peripheral concern.

PSD employee Stonestreet arrived late to the meeting because he had been investigating a possible petroleum of chemical spill in the Buffalo Creek watershed near the Town of Clay. Timber harvest has been ongoing in that watershed, which is upstream of the Clay Roane PSD intake.

Acting board chair Susan Beard signed protection plan signature page. Tetra Tech will assemble plan final document and submit to DHHR electronically.

*Do your part to keep
contaminants out of our
children's source water!*



Contaminants

Cleaning Products

Automotive Products

Fuel Oil

Furniture Strippers

Oil-based Paints

Sewage

Lawn and Garden Products

Sediments

Pharmaceuticals

Source Water Links

www.wvdhhr.org/oehs/eed/swap/
www.epa.gov/safewater/index.html
www.epa.gov/watersense/
<http://orsanco.org>

For Kids

www.epa.gov/safewater/kids/index.html
www.epa.gov/watersense/kids/index.html
www.groundwater.org/kids/



Contacts

WV Department of Health and Human Resources
Source Water Assessment and Protection Program
350 Capitol Street, Room 313
Charleston, WV 25301-3713
phone: (304) 558-2981
fax: (304) 558-4322
e-mail: EEDSourceWaterProtection@wv.gov

*Do Your Part
Protect Your
Source Water
Protect Your
Health*



Prepared by Tetra Tech
In cooperation with the WVDHHR Source Water
Assessment and Protection Program

Drinking water is essential for life. Learn what you can do to protect your drinking water sources.

Making choices to protect and conserve the source of your drinking water will help keep you, your family, and neighbors safe and healthy now and in the future.

Do Your Part to Protect Source Water

- ✓ Recycle used oil and other automotive products at a service center. Don't pour them on the ground or down storm drains. Storm drains can lead directly to your source water.
- ✓ Fix leaks from your automobile and clean up spills.
- ✓ Apply fertilizers and pesticides as directed. Consider natural alternatives to chemicals.
- ✓ Don't flush pharmaceuticals. Dispose by mixing with coffee grounds or kitty litter, sealing in a container, and placing in the trash. Organize a collection day with a pharmacy and local police department.
- ✓ Take unwanted household chemical waste, such as cleaners, oils, and paints to proper waste collection sites. Don't dump down your sink, toilet, or storm drains. Consider organizing a collection day in your community.
- ✓ Check for leaks at heating fuel tanks and install pads to catch accidental leaks or spills.
- ✓ Report unused water wells to your utility or WVDHHR.
- ✓ Inspect your septic system regularly and pump every 5-10 years.



Do Your Part to Conserve Source Water

- ✓ Turn off the water when you brush your teeth and take shorter showers.
- ✓ Wash full loads of clothes and dishes.
- ✓ Don't use your toilet to flush trash.
- ✓ Fix leaking faucets, toilets, and lines. Consider installing toilets, faucets, and appliances designed to save water.
- ✓ Water your lawn and garden in the morning. Consider installing a rain barrel at your downspouts to collect rain to water your lawn and garden, instead of using treated water.
- ✓ Use native plants in landscape that don't need extra watering. Use mulch to hold moisture.
- ✓ Don't let your garden hose run when washing your car.
- ✓ Don't panic if you are asked to conserve during a drought. Your utility will respond to water shortages based on your normal water use. Running extra water in your home during a drought will make it more difficult to respond to the water shortage.



Conserving water saves on your monthly bill now. Protecting your source water will save on treatment costs later.